

ARCHIVIO

Rimoldi

CATALOGO PEZZI DI RICAMBIO
SPARE PARTS CATALOGUE
CATALOGUE RECHANGES
ERSATZTEILELISTE

329-00-2CD-05

329-00-2CD-01

329-00-2CD-02

329-00-2CD-08

329-00-2CD-15

329-01-2CD-01

329-12-2CD-02

329-22-2CD-03

329-23-2CD-03

329-00-2CD-03

329-00-2CD-04

329-00-2CD-09

329-00-2CD-11

329-22-2CD-02

329-23-2CD-02

329-00-2CD-06

329-00-2CD-07

329-00-2CD-13

329-01-2CD-02

329-22-2CD-04

329-23-2CD-04

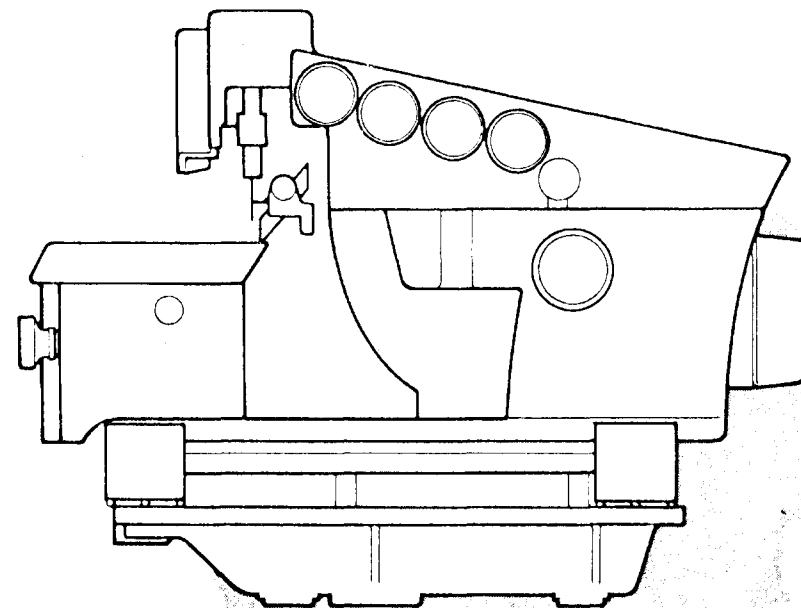

n. 62

652290520

UFFICIO CATALOGHI 7/77

Il presente Catalogo Pezzi di Ricambio è costituito da due parti: la prima, definita come "Catalogo base" (da Tav. 1 a Tav. 17), comprende i particolari montati sulla testa più significativa (la prima dell'elenco in copertina); la seconda (da Tav. 18 in avanti) comprende tutti i particolari delle altre teste basi o derivate, che differiscono da quella del Catalogo base.

Le Teste basi sono elencate in copertina con un carattere più grande rispetto a quello delle derivate.

Nella consultazione del Catalogo tenere presente che:

1. Tutti i particolari non fornibili scolti non vengono richiamati singolarmente, ma soltanto illustrati nel gruppo d'appartenenza.
2. I riferimenti delle figure dei particolari che compongono il gruppo sono di norma raggruppati in una parentesi. In alcuni casi però, dove non è possibile il raggruppamento, i numeri che nelle tavole illustrative richiamano i singoli pezzi sono affiancati dallo stesso segno particolare, con cui è indicato l'intero gruppo.
3. Sulle tavole relative alle altre teste (da Tav. 18 in avanti) sono elencati tutti i particolari diversi o non montati sulle teste del Catalogo Base.
Dette tavole portano in alto a destra il simbolo della testa cui si riferiscono.
I disegni di questo gruppo di tavole illustrano soltanto i pezzi nuovi o sostanzialmente diversi rispetto a quelli montati sulla testa più significativa del Catalogo.
I particolari richiamati come simbolo, ma non illustrati, conservano lo stesso numero di figura dei corrispondenti raffigurati sul Catalogo base.
I particolari comuni a tutte le teste comprese nel Catalogo, vengono richiamati soltanto nel primo gruppo di tavole e cioè da Tav. 1 a Tav. 17.
I particolari definiti come "pezzi annullati" si intendono quelli non montati sulla testa a cui la tavola si riferisce. Nel caso di un gruppo annullato, viene indicato soltanto il simbolo del gruppo, ma devono intendersi annullati anche tutti i particolari componenti il gruppo stesso.

Per facilitare la ricerca viene riportato l'indice numerico di tutti i particolari illustrati sul Catalogo base, con la relativa tavola in cui gli stessi sono richiamati.

AGHI

Gli aghi sono contraddistinti dal sistema e dalla finezza, la quale indica il diametro medio espresso in centesimi di millimetro.

Il sistema dell'ago e la finezza sono marcati oltre che sulla busta, anche sull'ago stesso.

Nelle ordinazioni precisare, oltre il simbolo, il sistema e la finezza degli aghi desiderati. In caso di dubbio, allegare, un ago campione o una bustina vuota.

AVVERTENZA

Nella richiesta di parti di ricambio citare sempre il relativo numero di matricola della macchina, il simbolo del particolare e la denominazione ufficiale usata sul catalogo.

This spare parts catalogue is made up of two parts: in the first one, called "basic catalogue" (from Table 1 to Table 17), all the details of most representative head are listed (the first head listed on the cover); the second one (from Table 18 onwards) includes the details of the other main heads or derived ones, which are different from that of the basic catalogue. The main heads are listed on the cover in bigger lettering to distinguish them from the derived heads.

When you consult the catalogue will you please note that:

1. all parts which cannot be supplied by themselves are not indicated alone, but shown together with the group to which they belong;
2. the references of the pictures of the parts making up the group are usually put in brackets.
In some cases, however, when their grouping is not possible, the numbers of the various parts in the tables are marked with the same particular sign with which the whole group is indicated.
3. In the tables of the other heads (from Table 18 onward) there are listed all the parts not fitted on the heads in the basic catalogue.
These tables are marked at the top right-hand corner with the symbol of the head which the table refers to.
The drawings in this group of tables show only the parts which are new or basically different from those fitted on the most representative head in the catalogue.
The parts which are represented only by the symbol but not illustrated keep the same figure number as the corresponding parts shown in the basic catalogue.
The parts which are common to all the heads in the catalogue are listed only in the first group of tables, that is from Table 1 to Table 17.
Parts marked "annulled part" are those not fitted on the head which the table refers to.
When an assembly has been annulled only the assembly symbol is specified, but all the parts forming the assembly must also be considered annulled.

To make it easier to locate the parts, the reference numbers of all of those shown in the basic catalogue are listed together with the number of the table in which they are to be found.

NEEDLES

The needles are marked with system and size; the size indicates the average diameter in hundredths of a millimeter.

The system and size of the needle are shown on the packet as well as on the needle itself. When ordering please state symbol, system and size. If you have doubts, enclose a sample needle or an empty packet with your order.

ATTENTION

When ordering spare parts always state the serial number of the machine, the symbol of the part in question and the description given in the catalogue.

TAV. N. TAB. N.	DESCRIZIONE	DESCRIPTION
1	BASE E BUSSOLE	BASE AND BUSHES
2	PIANO DI LAVORO	WORKING PLATE
3	COPERCHI E SPORTELLI	COVERS AND DOORS
4	COPERCHIO SUP - TENSIONI - PASSAFILI	UPPER COVER - TENSION - THREAD GUIDE
5	ALBERO PRINCIPALE	MAIN SHAFT
6	TRASPORTO	TRANSPORT
7	MOVIMENTO CROCHET	LOOPER GROUP
8	MOVIMENTO CROCHET SICUREZZA	SECURITY LOOPER GROUP
9	MOVIMENTO BARRA AGO	NEEDLE BAR
10	GRUPPO PREMISTOFFA	PRESSER ASSEMBLY
11	GRUPPO COLTELLI	KNIFE ASSEMBLY
12	GRUPPO LUBRIFICAZIONE	LUBRICATION
13	ORGANI CUCITURA	SEWING PARTS
14	ACCESSORI IN DOTAZIONE	AUXILIARY EQUIPMENT
15	PIASTRA PORTA TESTA	HEAD HOLDER PLATE
16	GINOCCHIELLO	KNEE - PRESS
17	PORTA BOBINE	BOBBIN CARRIER
18	TESTA 329-00-2CD-01	329-00-2CD-01 HEAD
19	TESTA 329-00-2CD-02	329-00-2CD-02 HEAD
20	TESTA 329-00-2CD-08	329-00-2CD-08 HEAD
21	TESTA 329-00-2CD-15	329-00-2CD-15 HEAD
22	TESTA 329-01-2CD-01	329-01-2CD-01 HEAD
23	TESTA 329-12-2CD-02	329-12-2CD-02 HEAD
24	TESTA 329-22-2CD-03	329-22-2CD-03 HEAD
25	TESTA 329-23-2CD-03	329-23-2CD-03 HEAD
26	TESTA 329-00-2CD-03 (BASE)	329-00-2CD-03 BASIC HEAD
27	TESTA 329-00-2CD-04	329-00-2CD-04 HEAD
28	TESTA 329-00-2CD-09	329-00-2CD-09 HEAD
29	TESTA 329-00-2CD-11	329-00-2CD-11 HEAD
30	TESTA 329-22-2CD-02	329-22-2CD-02 HEAD
31	TESTA 329-23-2CD-02	329-23-2CD-02 HEAD
32	TESTA 329-00-2CD-06 (BASE)	329-00-2CD-06 BASIC HEAD
33	TESTA 329-00-2CD-07	329-00-2CD-07 HEAD
34	TESTA 329-00-2CD-13	329-00-2CD-13 HEAD
35	TESTA 329-01-2CD-02	329-01-2CD-02 HEAD
36	TESTA 329-22-2CD-04	329-22-2CD-04 HEAD
37	TESTA 329-23-2CD-04	329-23-2CD-04 HEAD

CARATTERISTICHE TESTE MACHINE HEAD FEATURES	N. Aghi Needles N.	N. Fili Threads N.	Largh. costa Bight width	Posiz. Differ. Differ. posit.	g/1' max Max r.p.m.	N. punti per pollice Stitch per inch.	CARATTERISTICHE TESTA MACHINE HEAD FEATURES	N. Aghi Needles N.	N. Fili Threads N.	Largh. costa Bight width	Posiz. Differ. Differ. Posit.	g/1' max Max r.p.m.	N. punti per pollice Stitch per inch.
<p>329-00-2CD-01</p> <p>Come la 329-00-2CD-05 ma per tessuti rigidi leggeri in trama e ordito e tessuti trattati "permanent press" (teleria leggera, ecc.)</p> <p>Same as 329-00-2CD-05, but for light woven fabrics and for fabrics which have undergone permanent press processing (light, linen and cloth, etc.)</p>	2	4/5	3,5	- 1	7100	7÷20	<p>329-00-2CD-06</p> <p>Per cuciture di assemblaggio su tessuti rigidi pesanti in trama e ordito e tessuti trattati "permanent press" (pantaloni sportivi, gonne ecc.). Dotata di crochet per lavorare anche a 5 fili.</p> <p>For assembly seaming on heavy woven fabrics and on fabrics which have undergone permanent press processing (sports trousers, skirts, etc.). Fitted with looper to work also with 5 threads.</p>	2	4/5	5,5	- 1	6500	7÷20
<p>329-00-2CD-02</p> <p>Come la 329-00-2CD-05, ma particolarmente indicata per l'esecuzione di cuciture curve (camiceria).</p> <p>Same as 329-00-2CD-05, but particularly suitable for executing curved seams (for shirt making-up).</p>	2	4/5	3,7	- 1	7100	7÷20	<p>329-00-2CD-07</p> <p>Come la 329-00-2CD-06 ma particolarmente indicata per la chiusura dei fianchi dei pantaloni sportivi con tasche già inserite.</p>	2	4/5	5	0	6500	7÷20
<p>329-00-2CD-03</p> <p>Per cuciture di assemblaggio su tessuti rigidi leggerissimi in trama e ordito e su tessuti trattati "permanent press" (teleria leggera). Dotata di crochet per lavorare anche a 5 fili.</p> <p>For assembly seaming on very light woven fabrics and on fabrics which have undergone permanent press processing (light linen and cloth). Fitted with looper to work also with 5 threads.</p>	2	4/5	3	- 1	7500	10÷30	<p>Same as 329-00-2CD-06, but particularly suitable for closing the sides of sports trousers with pockets already inserted.</p> <p>329-00-2CD-08</p> <p>Per tessuti leggeri e medi facilmente sfilacciabili. Risvolta verso il basso i lembi del tessuto all'interno della cucitura. Come la 329-00-2CD-05 ma per risvoltare verso il basso.</p>	2	4/5	3,5	- 1	7100	7÷20
<p>329-00-2CD-04</p> <p>Come la 329-00-2CD-03 ma particolarmente indicata per l'esecuzione di cuciture curve (applicazione delle maniche di camicie).</p> <p>Same as 329-00-2CD-03, but particularly suitable for executing curved seams (attaching of shirt sleeves).</p>	2	4/5	3	- 1	7500	10÷30	<p>For light and medium woven fabrics which fray easily at the edges. It curls the edges downwards inside the seam. Fitted with looper to work also with 5 threads. Similar to 329-00-2CD-05, but for curling downwards.</p> <p>329-00-2CD-09</p> <p>Per tessuti leggerissimi facilmente sfilacciabili. Risvolta verso il basso i lembi del tessuto all'interno della cucitura. Dotata di crochet per lavorare anche a 5 fili. Come la 329-00-2CD-01 ma per risvoltare verso il basso.</p> <p>For very light woven fabrics which fray easily at the edges. It curls the edges downwards inside the seam. Fitted with looper to work also with 5 threads. Similar to 329-00-2CD-01, but for curling downwards.</p>	2	4/5	2,5	- 1	7500	10÷30
<p>329-00-2CD-05</p> <p>Per cuciture di assemblaggio su tessuti rigidi medi in trama e ordito (foderame e telerie) dotata di crochet per lavorare anche a 5 fili.</p> <p>For assembly seaming on medium woven fabrics (linings, linen and cloth). Fitted with looper to work also with 5 threads.</p>	2	4/5	5 (4)	- 1	7100	7÷20							

CARATTERISTICHE TESTE MACHINE HEAD FEATURES	N. Aghi Needles N.	N. Fili Threads N.	Largh. costa Bight width	Posiz. Differ. Differ. posit.	g/1' max Max r.p.m.	N. punti per pollice Stitch per inch.	CARATTERISTICHE TESTA MACHINE HEAD FEATURES	N. Aghi Needles N.	N. Fili Threads N.	Largh. costa Bight width	Posiz. Differ. Differ. Posit.	g/1' max Max r.p.m.	N. punti per pollice Stitch per inch.
<p>329-00-2CD-11</p> <p>Come la 329-00-2CD-09 ma particolarmente indicata per cuciture curve (applicazione delle maniche delle camicie).</p> <p>Same as 329-00-2CD-09, but particularly suitable for executing curved seams (for attaching shirt sleeves).</p>	2	4/5	3	- 1	7500	10÷30	<p>329-00-2CD-02</p> <p>Per inserire nella cucitura una fettuccia di rinforzo di larghezza max 10 mm. Particolarmente indicata per rinforzo cuciture spalle su tessuti medi e pesanti di maglia. Dotata di crochet per lavorare anche a 5 fili.</p> <p>To insert into the seam a reinforcing tape, 10 mm max. width. Particularly suitable for reinforcing shoulder seams on medium and heavy knit fabrics. Equipped with looper to work also with 5 threads.</p>	2	4/5	5,5	- 1	6500	7÷30
<p>329-00-2CD-13</p> <p>Per cuciture di assemblaggio su tessuti rigidi pesanti in trama e ordito e tessuti trattati "permanent press" (pantaloni sportivi, gonne ecc.). Dotata di crochet per lavorare anche a 5 fili.</p> <p>For assembly seaming of heavy woven fabrics and fabrics which have undergone permanent press processing (sport trousers, skirts, etc.). Equipped with looper to work also with 5 threads.</p>	2	4/5	5	- 1	6500	7÷20	<p>329-12-2CD-02</p> <p>Per chiudere a sacco le fodere delle tasche dei pantaloni, inserendo all'interno del soprappetto una fettuccia ripiegata a U mediante un'apposita guida saldata sulla placca ago. La cucitura si presenta come una specie di bordatura.</p> <p>For closing the trouser pocket linings inserting inside the overedge seam a U-folded strip of fabric by a special folder welded on the needle plate. The finished seam looks like a kind of lining.</p>	2	4/5	4,5	- 1	6500	7÷20
<p>329-00-2CD-15</p> <p>Per cuciture di assemblaggio su tessuti rigidi medi e leggeri in trama e ordito. Dotata di crochet per lavorare a 5 fili.</p> <p>For assembly seaming of medium and light woven fabrics. Fitted with looper to work also with 5 threads.</p>	2	4/5	6	- 1	7500	7÷20	<p>329-22-2CD-02</p> <p>Per tessuti in trama e ordito leggerissimi non sfilacciabili. Muniti di dispositivo (ribaltabile) per arricciare il lembo inferiore. Dotata di ginocchietto che agendo sul differenziale permette di variare il rapporto di arricciatura a macchina in moto. Tale effetto si ottiene con una lamina premente sulla griffa differenziale. Con crochet per lavorare anche a 5 fili.</p> <p>For very light woven fabrics which do not fray at the edges. Fitted with swing-out device for ruffling the lower layer. With knee press control which acting on differential feed, ensures variation of ruffling ratio while the machine is running. The effect is obtained by means of a sheet pressing on the differential feed dog. With looper to work also with 5 threads.</p>	2	4/5	3	- 1	6500	8÷20
<p>329-01-2CD-01</p> <p>Per inserire nella cucitura una fettuccia di rinforzo di larghezza max 8 mm. Particolarmente indicata per rinforzo cuciture spalle su tessuti medi e pesanti di maglia. Dotata di crochet per lavorare anche a 5 fili.</p> <p>For inserting into the seam a reinforcing tape, 8 mm maximum width. Particularly suitable for reinforcing shoulder seams on medium and heavy knit fabrics. Fitted with looper to work also with 5 threads.</p>	2	4/5	4	- 1	7100	7÷30							

CARATTERISTICHE TESTE MACHINE HEAD FEATURES	N. Aghi Needles N.	N. Fili Threads N.	Largh. costa Bight width	Posiz. Differ. Differ. posit.	g/1' max Max r.p.m.	N. punti per pollice Stitch per inch.	CARATTERISTICHE TESTA MACHINE HEAD FEATURES	N. Aghi Needles N.	N. Fili Threads N.	Largh. costa Bight width	Posiz. Differ. Differ. Posit.	g/1' max Max r.p.m.	N. punti per pollice Stitch per inch.
<p>329-22-2CD-03</p> <p>Per tessuti in trama e ordito medi non sfilacciabili e con distanza aghi 2,5 mm. Munita di dispositivo (ribaltabile) per arricciare il lembo inferiore. Dotata di ginocchiello che agendo sul differenziale permette di variare il rapporto di arricciatura a macchina in moto. Tale effetto si ottiene con una lamina premente sulla griffa differenziale. Con crochet per lavorare anche a 5 fili.</p> <p>For medium woven fabrics which do not fray at the edges. Fitted with swing-out device for ruffling the lower layer. With knee press control which, acting on differential feed, ensures variation of ruffling ratio while the machine is running. The effect is obtained by means of a sheet pressing on the differential feed dog. With looper to work also with 5 threads.</p>	2	4/5	3	- 1	6500	8÷20	<p>329-23-2CD-03</p> <p>Per tessuti in trama e ordito medi non sfilacciabili. Munita di dispositivo (ribaltabile) per arricciare il lembo inferiore inserendo contemporaneamente un cordoncino all'interno di una fettuccia piegata ad U che a lembi ribaltati funge da ornamento. Dotata di ginocchiello che agendo sul differenziale permette di variare il rapporto di arricciatura a macchina in moto. Dotata di crochet per lavorare anche a 5 fili.</p> <p>For medium woven fabrics which do not fray at the edges. With swing-out device to ruffle the lower layer inserting simultaneously a piping cord inside a U-folded tape giving, when the two layers are opened out, a decorative effect. Fitted with knee press control which, acting on the differential feed, ensures the variation of the ruffling ratio while the machine is running. With looper to work also with 5 threads.</p>	2	4/5	6 (4,5)	- 1	6500	8÷20
<p>329-22-2CD-04</p> <p>Come la 329-22-2CD-02 ma per tessuti pesanti non sfilacciabili e con distanza aghi 5 mm.</p> <p>Same as 329-22-2CD-02, but for heavy fabrics which do not fray at the edges. With 5 mm needle gauge.</p>	2	4/5	5	- 1	6500	8÷20	<p>329-23-2CD-04</p> <p>Come la 329-23-2CD-02 ma per tessuti non sfilacciabili e con distanza aghi 5 mm.</p> <p>Same as 329-23-2CD-02, but for heavy fabrics which do not fray at the edges. With 5 mm. needle gauge.</p>	2	4/5	5	- 1	6500	8÷20
<p>329-23-2CD-02</p> <p>Per tessuti in trama e ordito leggerissimi non sfilacciabili. Munita di dispositivo (ribaltabile) per arricciare il lembo inferiore inserendo contemporaneamente un cordoncino all'interno di una fettuccia piegata ad U che a lembi ribaltati funge da ornamento. Dotata di ginocchiello che agendo sul differenziale, permette di variare il rapporto di arricciatura a macchina in moto. Con crochet per lavorare anche a 5 fili. Come la 329-22-2CD-02 ma per inserire fettuccia e cordoncino.</p> <p>For very light woven fabrics which do not fray at the edges. With swing-out device to ruffle the lower layer inserting simultaneously a piping cord inside a U-folded tape giving, when the two layers are opened out, a decorative effect. Fitted with knee press control which, acting on the differential feed, ensures the variation of the ruffling ratio while the machine is running.</p>	2	4/5	3	- 1	6500	8÷20							

Rumoldi

INDICE NUMERICO INDEX

Part. N.	Tav. N.	Part. N.	Tav. N.	Part. N.	Tav. N.	Part. N.	Tav. N.	Part. N.	Tav. N.	Part. N.	Tav. N.	Part. N.	Tav. N.
100620-0-10	6	202408-0-10	6	204676-0-10	13	204855-4-10	8	206508-0-00	5	206586-0-00	6	206645-4-00	7
200490-0-00	6	202412-0-10	6	204681-0-10	11	204861-0-10	13	206509-3-00	12	206587-0-00	6	206646-0-00	7
201128-0-10	7	202413-0-11	13	204685-2-10	11	204862-4-10	13	206510-4-00	12	206588-0-00	6	206651-0-00	1
201236-0-10	13	202472-0-10	6	204687-0-10	11	204863-0-10	13	206514-0-00	9	206592-3-00	6	206652-2-00	7
201358-0-10	6	202473-0-10	6	204690-0-10	11	204864-0-10	13	206516-0-00	9	206593-0-00	6	206656-0-00	7
201610-0-01	6	202475-0-10	6	204691-0-10	11	204869-0-10	13	206518-0-00	9	206594-0-00	1	206658-2-00	7
202026-0-10	2	202478-0-10	6	204693-0-11	13	204878-0-10	13	206522-3-00	9	206595-0-00	1	206659-2-00	7
202027-0-10	3	202480-0-10	3	204694-0-10	13	204889-0-10	13	206524-0-00	9	206598-3-00	6	206665-2-00	12
202032-0-10	6	202484-0-10	3	204699-0-11	11	204891-0-11	10	206525-3-00	9	206599-0-00	6	206666-0-00	12
202033-0-10	6	202487-0-10	8	204700-0-10	7	204894-0-10	13	206529-4-00	9	206603-0-10	6	206667-0-00	12
202047-2-10	6	202488-0-10	6	204704-0-10	4	204895-0-10	13	206530-4-00	9	206605-0-01	6	206669-2-01	12
202063-0-10	6	202489-0-10	6	204729-0-10	8	204905-0-10	6	206531-0-00	9	206606-2-00	6-9	206679-0-00	5
202065-0-10	1	202490-0-10	6	204747-0-10	4	204911-0-11	4	206532-0-00	5	206608-0-00	6	206681-0-00	5
202071-2-10	5	202492-0-10	5	204748-4-11	4	204912-0-10	8	206533-0-00	9	206609-0-00	6	206682-0-00	1
202086-0-10	7	202529-0-10	10	204750-0-10	4	204913-0-10	8	206534-0-00	2	206613-0-00	6	206683-0-00	5
202092-0-10	13	202539-4-00	5	204753-0-10	4	204919-4-10	13	206535-0-00	4	206614-2-00	6	206684-0-00	5
202110-0-10	10	202556-0-00	4	204755-0-10	8	204920-2-10	13	206538-0-00	1	206615-4-00	6	206685-0-00	3
202128-0-10	11	202558-2-00	4	204755-2-10	8	204940-0-10	13	206539-0-00	1	206617-0-00	6	206686-0-00	7
202129-0-10	11	202572-4-11	11	204756-0-10	4	204941-0-10	13	206540-2-00	9	206618-0-00	6	206687-2-00	3
202130-0-10	11	202609-0-10	13	204757-0-11	5	204942-0-10	13	206544-0-00	5	206619-0-00	6	206688-0-00	3
202131-0-10	11	202681-0-10	4	204759-2-10	4	204943-0-11	13	206546-0-00	6	206620-0-00	10	206689-0-00	5
202165-0-10	3	202683-0-10	4	204760-4-10	4	204947-0-10	13	206549-2-00	5	206621-0-00	10	206690-2-00	5
202194-0-10	10	202720-0-00	7	204761-0-10	4	204950-3-11	13	206550-4-00	12	206622-0-00	10	206692-0-00	5
202214-0-10	3-10	202960-4-10	13	204762-0-11	8	204984-0-10	13	206555-0-00	12	206623-2-11	10	206693-0-11	5
202225-0-10	4	202968-0-10	13	204764-3-10	8	204997-0-00	13	206556-0-00	5	206625-0-00	10	206695-0-00	7
202227-0-10	4	202970-0-10	13	204768-0-10	1	205021-0-10	10	206557-0-00	12	206626-3-00	10	206696-0-00	10
202228-0-10	4	203187-0-10	10	204769-0-10	8	206257-4-00	4	206559-0-00	12	206628-0-00	1	206697-4-01	5
202229-0-10	4	203457-0-10	10	204770-0-10	1	206317-3-00	4	206560-0-00	12	206629-0-00	1-10	206699-0-00	5
202256-0-10	4	203630-0-10	4	204771-0-10	1	206340-4-00	4	206564-0-00	12	206630-2-01	10	206705-3-00	5
202257-0-10	4	203635-0-10	4	204773-0-10	8	206341-4-00	4	206565-0-00	12	206632-2-00	10	206708-0-00	5
202258-0-10	4	203647-2-11	4	204776-0-10	8	206342-4-00	4	206566-0-00	12	206633-0-00	10	206711-0-00	4
202260-0-10	4	203759-0-10	13	204778-3-10	8	206343-4-00	4	206567-0-00	12	206634-0-00	10	206713-2-00	4
202282-0-10	4	203760-0-10	13	204781-0-10	1	206346-4-00	4	206568-0-00	12	206635-0-00	10	206714-2-00	4
202352-2-11	5	203783-0-10	13-14	204787-0-10	8	206356-4-00	3	206569-0-00	12	206636-0-00	10	206715-0-00	2
202371-0-10	1	203784-0-10	13	204798-0-20	1	206386-4-00	7	206560-0-00	12	206637-0-00	10	206716-0-00	2
202385-0-10	6	204033-0-10	13	204799-0-10	11	206410-3-00	7	206574-2-00	11	206638-4-00	10	206722-2-00	2
202386-0-10	5	204122-0-10	5	204800-0-10	8	206415-4-00	7	206578-2-00	5	206639-0-00	10	206723-4-00	2
202391-0-10	10	204659-0-10	8	204803-0-10	5	206429-4-00	9	206580-2-00	6	206640-0-00	10	206725-2-00	2
202393-0-10	2	204671-0-10	7	204846-0-10	13	206447-4-01	10	206586-3-00	6	206642-0-00	10-12	206726-0-00	2
202395-0-10	16	204674-3-10	8	204850-0-10	13	206506-0-00	9	206583-0-00	6	206643-0-00	5	206727-0-00	2
202398-0-10	2	204675-0-10	13	204851-0-11	13	206507-0-00	5	206584-2-00	6	206644-2-00	10	206730-0-00	3

CARATTERISTICHE TESTE MACHINE HEAD FEATURES	N. Aghi Needles N.	N. Fili Threads N.	Largh.costa Bight width	Posiz.Differ. Differ.posit.	g/1' max Max r.p.m.	N.punti per pollice Stitch per inch.	CARATTERISTICHE TESTA MACHINE HEAD FEATURES	N. Aghi Needles N.	N. Fili Threads N.	Largh.costa Bight width	Posiz.Differ. Differ.Posit.	g/1' max Max r.p.m.	N.punti per pollice Stitch per inch.
<p>329-22-2CD-03</p> <p>Per tessuti in trama e ordito medi non sfilacciabili e con distanza aghi 2,5 mm. Munita di dispositivo (ribaltabile) per arricciare il lembo inferiore. Dotata di ginocchiello che agendo sul differenziale permette di variare il rapporto di arricciatura a macchina in moto. Tale effetto si ottiene con una lamina premente sulla griffa differenziale. Con crochet per lavorare anche a 5 fili.</p> <p>For medium woven fabrics which do not fray at the edges. Fitted with swing-out device for ruffling the lower layer. With knee press control which, acting on differential feed, ensures variation of ruffling ratio while the machine is running. The effect is obtained by means of a sheet pressing on the differential feed dog. With looper to work also with 5 threads.</p>	2	4/5	3	- 1	6500	8÷20	<p>329-23-2CD-03</p> <p>Per tessuti in trama e ordito medi non sfilacciabili. Munita di dispositivo (ribaltabile) per arricciare il lembo inferiore inserendo contemporaneamente un cordoncino all'interno di una fettuccia piegata ad U che a lembi ribaltati funge da ornamento. Dotata di ginocchiello che agendo sul differenziale permette di variare il rapporto di arricciatura a macchina in moto. Dotata di crochet per lavorare anche a 5 fili.</p> <p>For medium woven fabrics which do not fray at the edges. With swing-out device to ruffle the lower layer inserting simultaneously a piping cord inside a U-folded tape giving, when the two layers are opened out, a decorative effect. Fitted with knee press control which, acting on the differential feed, ensures the variation of the ruffling ratio while the machine is running. With looper to work also with 5 threads.</p>	2	4/5	6 (4,5)	- 1	6500	8÷20
<p>329-22-2CD-04</p> <p>Come la 329-22-2CD-02 ma per tessuti pesanti non sfilacciabili e con distanza aghi 5 mm.</p> <p>Same as 329-22-2CD-02, but for heavy fabrics which do not fray at the edges. With 5 mm needle gauge.</p>	2	4/5	5	- 1	6500	8÷20	<p>329-23-2CD-04</p> <p>Come la 329-23-2CD-02 ma per tessuti non sfilacciabili e con distanza aghi 5 mm.</p> <p>Same as 329-23-2CD-02, but for heavy fabrics which do not fray at the edges. With 5 mm. needle gauge.</p>	2	4/5	5	- 1	6500	8÷20
<p>329-23-2CD-02</p> <p>Per tessuti in trama e ordito leggerissimi non sfilacciabili. Munita di dispositivo (ribaltabile) per arricciare il lembo inferiore inserendo contemporaneamente un cordoncino all'interno di una fettuccia piegata ad U che a lembi ribaltati funge da ornamento. Dotata di ginocchiello che agendo sul differenziale, permette di variare il rapporto di arricciatura a macchina in moto. Con crochet per lavorare anche a 5 fili. Come la 329-22-2CD-02 ma per inserire fettuccia e cordoncino.</p> <p>For very light woven fabrics which do not fray at the edges. With swing-out device to ruffle the lower layer inserting simultaneously a piping cord inside a U-folded tape giving, when the two layers are opened out, a decorative effect. Fitted with knee press control which, acting on the differential feed, ensures the variation of the ruffling ratio while the machine is running.</p>	2	4/5	3	- 1	6500	8÷20							

Part. N.	Tav. N.	Part. N.	Tav. N.	Part. N.	Tav. N.	Part. N.	Tav. N.	Part. N.	Tav. N.	Part. N.	Tav. N.	Part. N.	Tav. N.
206733-0-00	3	206858-0-00	3	704424-2-00	15	722905-2-00	15	741956-2-00	5	778401-0-00	7	990179-4-11	15
206734-2-00	3	206860-0-00	5	704536-0-00	15	722917-2-00	15	742068-2-00	15	778406-0-00	5	990180-0-10	14
206735-0-00	3	206871-4-01	6	704802-0-00	11	724032-0-00	6-9	742222-2-00	6	778407-0-00	9	990181-0-10	14
206736-2-00	12	206872-0-00	6	704808-0-00	6	724422-2-00	4	742457-2-00	11	778408-0-00	8	990182-0-10	14
206739-0-00	12	206876-0-10	4	704813-0-00	12	724895-2-00	3	742758-0-00	11	778417-0-00	6-7	990183-0-12	14
206740-0-00	1	206880-2-00	3	704829-0-00	6	727002-0-00	7	743343-2-00	5	778421-0-00	8	990310-0-10	15
206742-4-00	12	206885-2-00	3	704813-0-00	8	727024-0-00	16	743464-2-00	13	778520-0-00	10	990311-0-10	15
206743-3-00	12	207003-2-00	13	704837-0-00	9	727096-0-00	10	743471-2-00	5	778832-0-00	1-11	990314-0-00	15
206744-0-00	2	207004-2-00	13	704841-0-00	6	727203-0-00	5	744332-2-00	6-9-10	778837-0-00	9	990316-0-10	15
206746-0-00	4	207020-2-01	13	704845-0-00	7	727706-0-00	9	744334-2-00	6-9-10	781305-0-20	3	990324-0-10	14
206747-0-01	4	208371-0-10	1	704847-0-00	7	728272-0-00	6	744530-0-00	8	788001-0-01	4	990325-0-10	14
206748-0-00	1	300218-0-10	4	705008-0-00	6	729011-2-00	4	744573-0-00	11	900201-0-10	15	990327-0-10	14
206750-0-00	12	300710-0-10	13	705013-0-00	4-7	729013-2-00	13	744621-0-00	6	900203-0-10	15	990335-0-10	11
206751-0-00	12	301586-0-10	10	705029-0-00	9-11	729032-2-00	6	744631-2-00	4	900204-0-10	15	990474-0-10	14
206752-0-00	12	700205-0-00	15	705201-0-00	6	729034-2-00	17	744634-0-00	13	900694-0-11	15	990577-0-10	14
206753-0-00	12	700206-0-00	16	705208-0-00	6	729051-2-00	6-10	744654-2-00	3	900918-0-00	16	990585-0-10	14
206754-0-00	4	700207-0-00	6	705230-0-00	6	729054-2-00	17	744742-0-00	2	900920-0-00	15	990622-0-10	14
206755-0-00	4	700208-0-00	8	705408-0-00	6	730023-2-00	3	745001-0-00	9	900925-4-01	15	990639-0-10	14
206756-0-00	3	700630-0-00	5	705925-0-00	3	731107-0-00	17	745002-0-00	4-7-9	900926-0-00	15	990685-0-10	14
206757-0-00	11	701002-0-00	6	705957-0-00	2	733008-2-00	15-16	745114-0-00	10	900927-0-00	15	990981-0-00	15
206758-0-10	11	701004-0-00	12	705977-0-00	12	733503-0-00	4	745124-0-00	8	900928-0-00	15	990982-0-00	15
206763-0-00	3	701005-0-00	12	720431-2-00	4	733505-2-00	4-10	745125-2-00	6	900929-0-01	15	990983-0-00	15
206764-0-00	3	701006-0-00	10	720464-4-00	15	733507-0-00	12-15	745126-2-00	2	900931-0-00	15	990984-4-00	15
206767-0-00	3	701007-0-00	6	720505-4-00	15	733508-2-00	15-17	745168-0-00	7	901101-0-00	15	990985-0-00	14
206768-0-00	3	701032-0-00	12	720545-4-00	15	733510-4-00	15	745800-2-00	3-5-7-8-9	901102-0-00	15	990986-4-00	15
206769-0-10	3	701050-0-00	12	720566-2-00	15	740035-0-00	16	745803-2-00	4	901103-0-00	15	990987-4-00	15
206770-0-00	3	701104-0-00	12	721424-2-00	4	740220-2-00	6	745812-2-00	6-7-8-9	901104-0-00	15	991106-0-00	17
206790-2-00	6	701113-0-00	7-12	721433-2-00	2	740230-2-00	2		10-12	901105-0-00	15	991107-0-00	17
206794-0-00	6	701116-0-00	5	721435-2-00	3	741400-0-00	4	746007-2-00	2-3-10-13	901120-2-00	15	991111-0-00	17
206795-0-00	6	701133-0-00	5	721443-2-00	6	741413-0-00	6-13	746008-0-00	6	901123-4-00	15	991112-0-00	17
206796-0-00	6	701151-0-00	12	721464-2-00	3-5-6-10-12	741431-0-00	13	746020-2-00	10	920103-0-10	16	991113-0-00	17
206797-0-00	6	701405-0-00	4	721474-2-00	12	741433-0-00	10	746208-2-00	3	920105-0-10	16	991114-0-00	17
206798-0-00	6	702406-0-00	13	721475-2-00	15	741520-0-10	11	746402-0-00	15	920106-0-10	16	991128-0-00	17
206799-0-00	6	702412-0-00	8	721484-2-00	12	741535-0-00	4	746408-2-00	7	920113-0-10	16	991135-6-00	17
206803-2-00	6	703005-0-00	17	721494-2-00	10	741539-0-00	4	746409-2-00	15	920114-0-10	16	991136-4-00	17
206804-0-00	6	703007-0-00	5	721514-0-00	1	741546-2-00	6	765200-6-90	9-14	920128-0-00	16	991137-2-00	17
206812-0-00	4	703210-0-00	9	721525-0-00	5	741559-2-00	4	765202-0-00	7	920230-0-00	16	991140-2-00	17
206827-4-00	9	704009-4-00	15	722431-2-00	17	741657-0-00	4	778203-0-00	9-10	920231-0-00	16	991144-3-00	17
206854-3-00	1	704345-2-00	15	722442-2-00	12	741682-0-00	3-4	778208-0-00	7	920232-2-00	16	991179-0-00	17
206856-0-00	1	704346-2-00	15	722471-2-00	11	741724-0-00	3	778236-0-00	7	920235-0-00	16	991186-0-00	15
206857-0-00	3	704409-0-00	11-15	722481-2-00	12	741745-2-00	3-6	778400-0-00	9	920236-0-00	16	991187-0-00	15
										920237-0-00	16	991188-0-00	15
										920241-0-00	16	991189-0-00	15
										920245-4-00	10		
										920246-4-00	11		
										920490-0-10	16		
										990074-1-10	14		
										990174-0-10	14		
										990174-0-10	14		

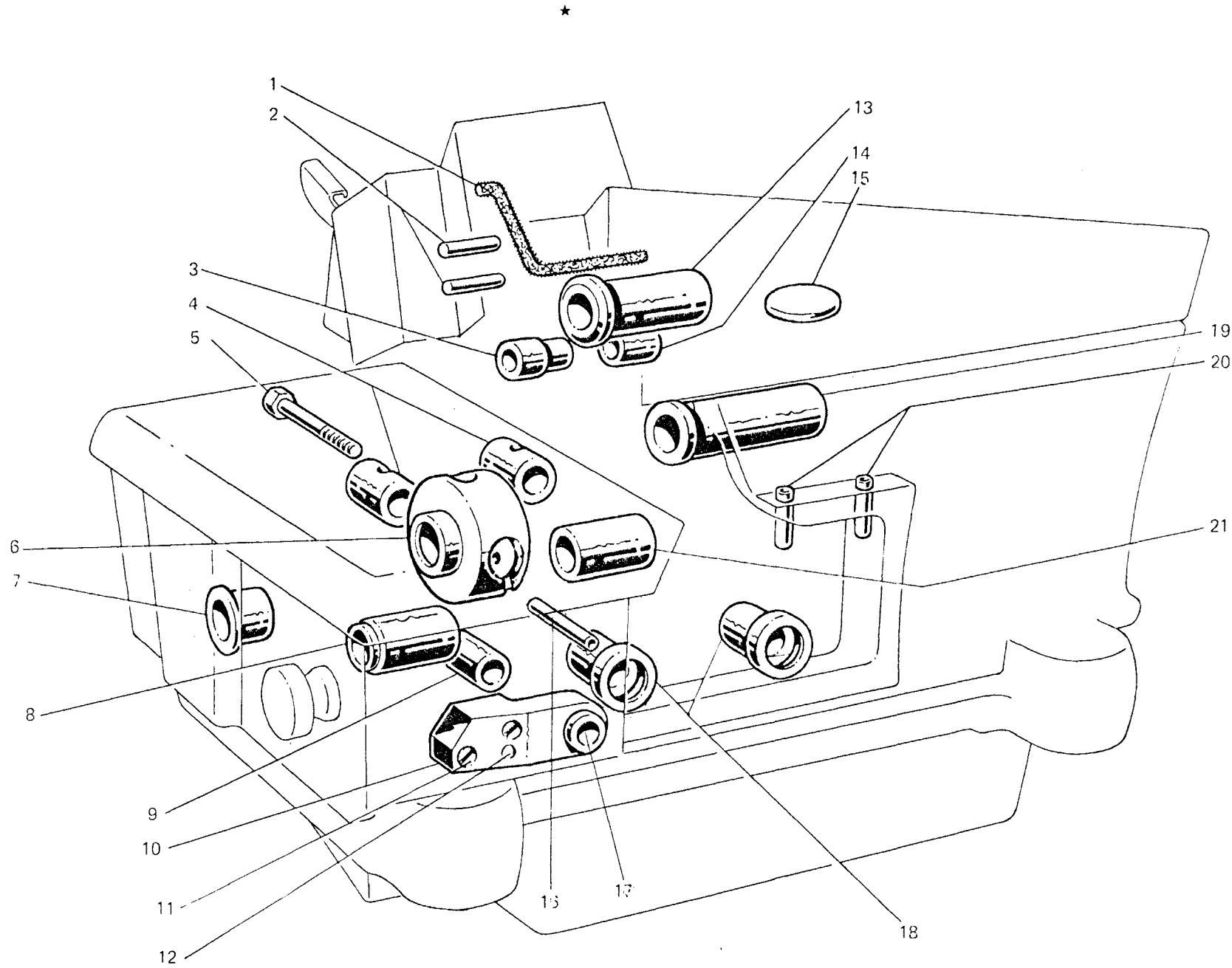

Fig. N. Abb. N.	Part. N. Bestell N. Piece N. Pieza N.	Qt. Anzahl	DESCRIZIONE	DESCRIPTION	BENENNUNG	DESCRIPTION	DESCRIPCION
★	206854-3-00	1	base con bussole e guidafili	base assembly			
1	778832-0-00	1	stoppino	wick			
2	202371-0-10	2	spina	pin			
3	206628-0-00	1	bussola	bush			
4	206651-0-00	2	bussola posteriore	rear bush			
5	204798-0-20	1	vite	screw			
6	206682-0-00	1	bussola intermedia	intermediary bush			
7	206595-0-00	1	bussola sinistra	left bush			
8	204768-0-10	1	bussola	bush			
9	204771-0-10	1	bussola	bush			
10	206856-0-00	1	blocchetto	block			
11	721514-0-00	2	vite	screw			
12	208371-0-10	1	spina	pin			
13	206538-0-00	1	bussola	bush			
14	206629-0-00	1	bussola destra	right bush			
15	206748-0-00	1	tappo ad espansione	plug			
16	204781-0-10	1	tubetto	pipe			
17	204770-0-10	1	bussola	bush			
18	202065-0-10	2	bussola anteriore	front bush			
19	206539-0-00	1	bussola	bush			
20	206740-0-00	2	passafile	thread guide			
21	206594-0-00	1	bussola	bush			

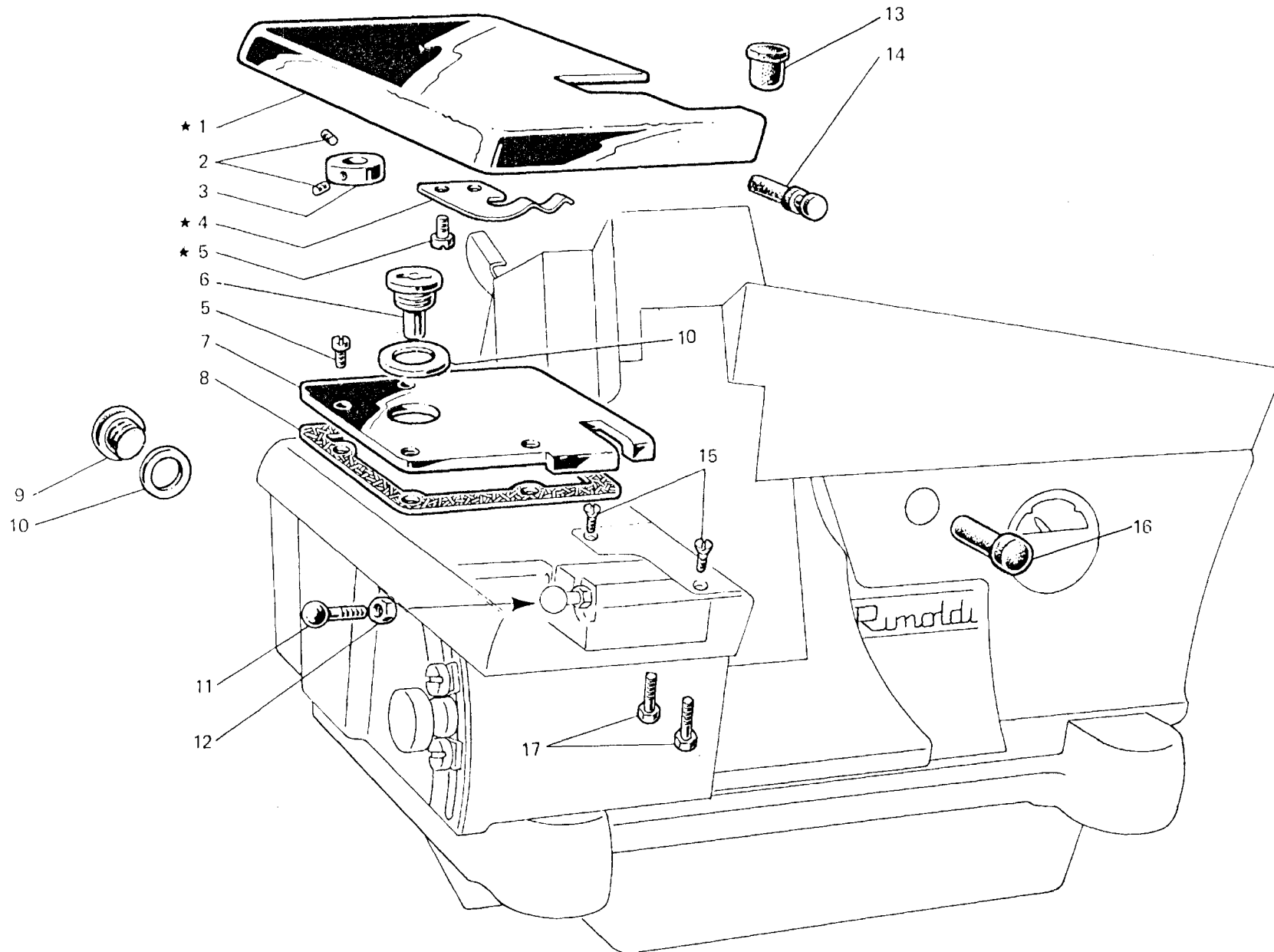

Fig. N. Abb. N.	Part. N. Bestell N. Piece N. Pieza N.	Qt. Anzahl	DESCRIZIONE	DESCRIPTION	BENENNUNG	DESCRIPTION	DESCRIPCION
★	206723-4-00	1	piano di lavoro completo	working assembly			
1	206722-2-00	1	piano di lavoro	working plate			
2	745126-2-00	2	vite	screw			
3	202393-0-10	1	anello	ring			
4	206716-0-00	1	molla	spring			
5	721433-2-00	6	vite	screw			
6	206727-0-00	1	tappo carico olio	plug			
7	206725-2-00	1	coperchio cinematismo	cover			
8	206726-0-00	1	guarnizione	gasket			
9	202026-0-10	1	tappo	plug			
10	705957-0-00	2	rondella cartone	washer			
11	206715-0-00	1	vite testa sferica	screw			
12	746007-2-00	1	dado	nut			
13	206744-0-00	1	tampone	pad			
14	206534-0-00	1	tappo	plug			
15	744742-0-00	2	vite per placca ago	screw for needle plate			
16	202398-0-10	1	tappo	plug			
17	740230-2-00	2	vite fissa salvo ago e spingi asola	screw for rear and front needle guard			

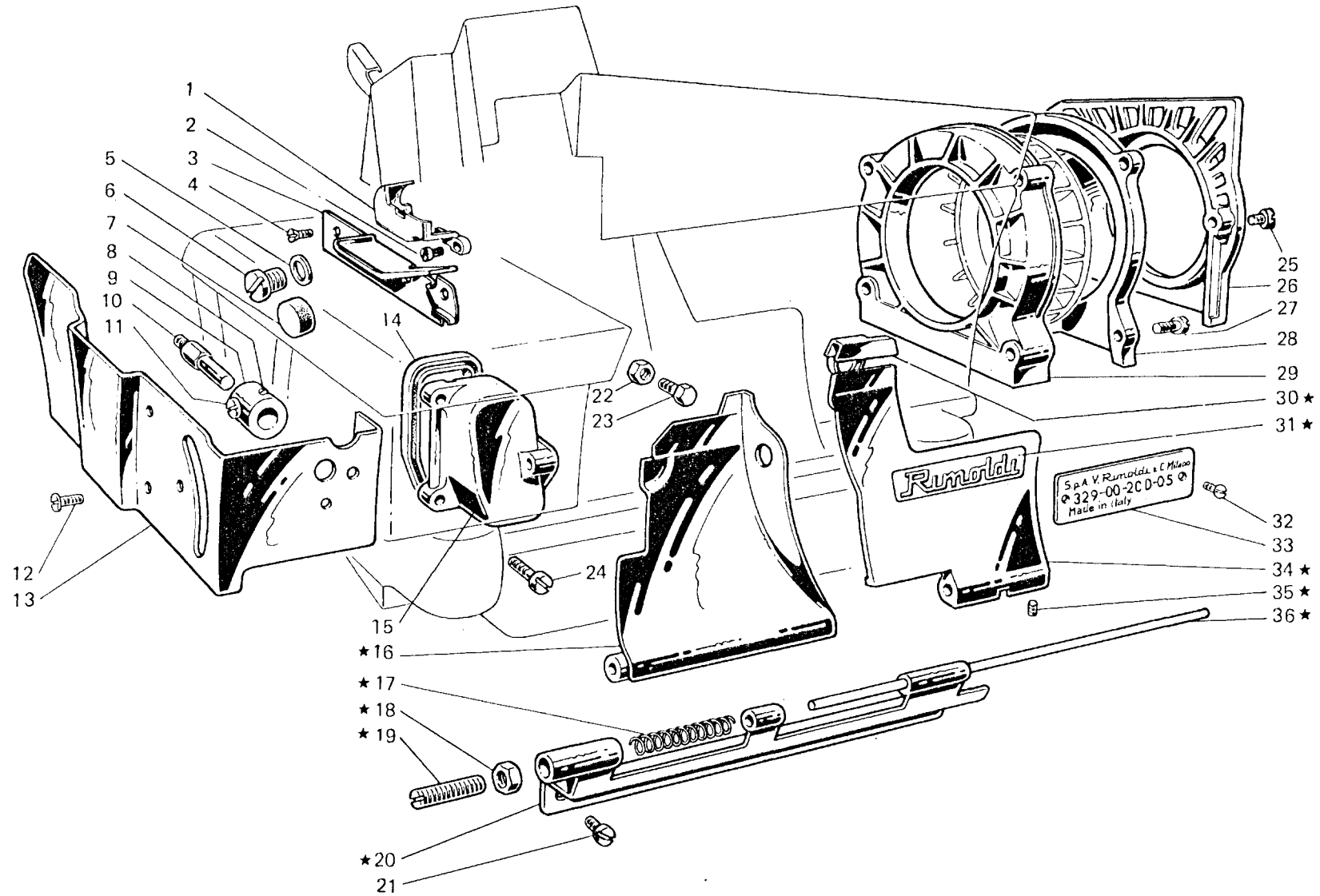

Fig. N. Abb. N.	Part. N. Bestell N. Piece N. Pieza N.	Qt. Anzahl	DESCRIZIONE	DESCRIPTION	BENENNUNG	DESCRIPTION	DESCRIPCION
★	206356-4-00	1	sportello ant. compl.	front cover assembly			
1	206730-0-11	1	vaschetta recupero olio	sump			
2	741745-2-00	2	vite	screw			
3	206735-0-00	1	carterino para olio	oil retainer			
4	744654-2-00	3	vite	screw			
5	705925-0-00	1	rondella in fibra	washer			
6	202480-0-10	1	tappo	plug			
7	202027-0-10	1	tappo	plug			
8	730023-2-00	1	vite	screw			
9	206734-2-00	1	morsetto fiss.carter laterale	side cover clamp			
10	206733-0-00	1	vite per carter laterale	screw			
11	721435-2-00	1	vite	screw			
12	724895-2-00	4	vite	screw			
13	206880-0-00	1	carter laterale completo	side cover assembly			
14	206858-0-00	1	guarnizione	gasket			
15	206857-0-00	1	carterino	cover			
16	206885-2-00	1	sportello scorrevole	sliding cover			
17	206768-0-00	1	molla	spring			
18	746208-2-00	1	dado	nut			
19	206769-0-10	1	vite di regolazione	adjusting screw			
20	206756-0-00	1	cerniera	clamp			
21	741724-0-00	4	vite	screw			
22	746007-2-00	1	dado	nut			
23	202214-0-10	1	vite	screw			
24	741682-0-00	2	vite	screw			
25	721464-2-00	2	vite per coperchio	screw			
26	206685-0-00	1	coperchio cinghia	cover			
27	202484-0-10	4	vite	screw			
28	206687-2-00	1	coperchio coclea	scroll cover			
29	206688-0-00	1	coclea per ventola	scroll			
30	206764-0-00	1	zoccolo	block			
31	206770-0-00	1	targhetta Rimoldi	Rimoldi plate			
32	202165-0-10	2	vite	screw			
33	781305-0-20	1	targhetta classe	head class plate			
34	206763-0-00	1	sportello ribaltabile	tipping cover			
35	745800-2-00	1	vite	screw			
36	206767-0-00	1	perno	pin			

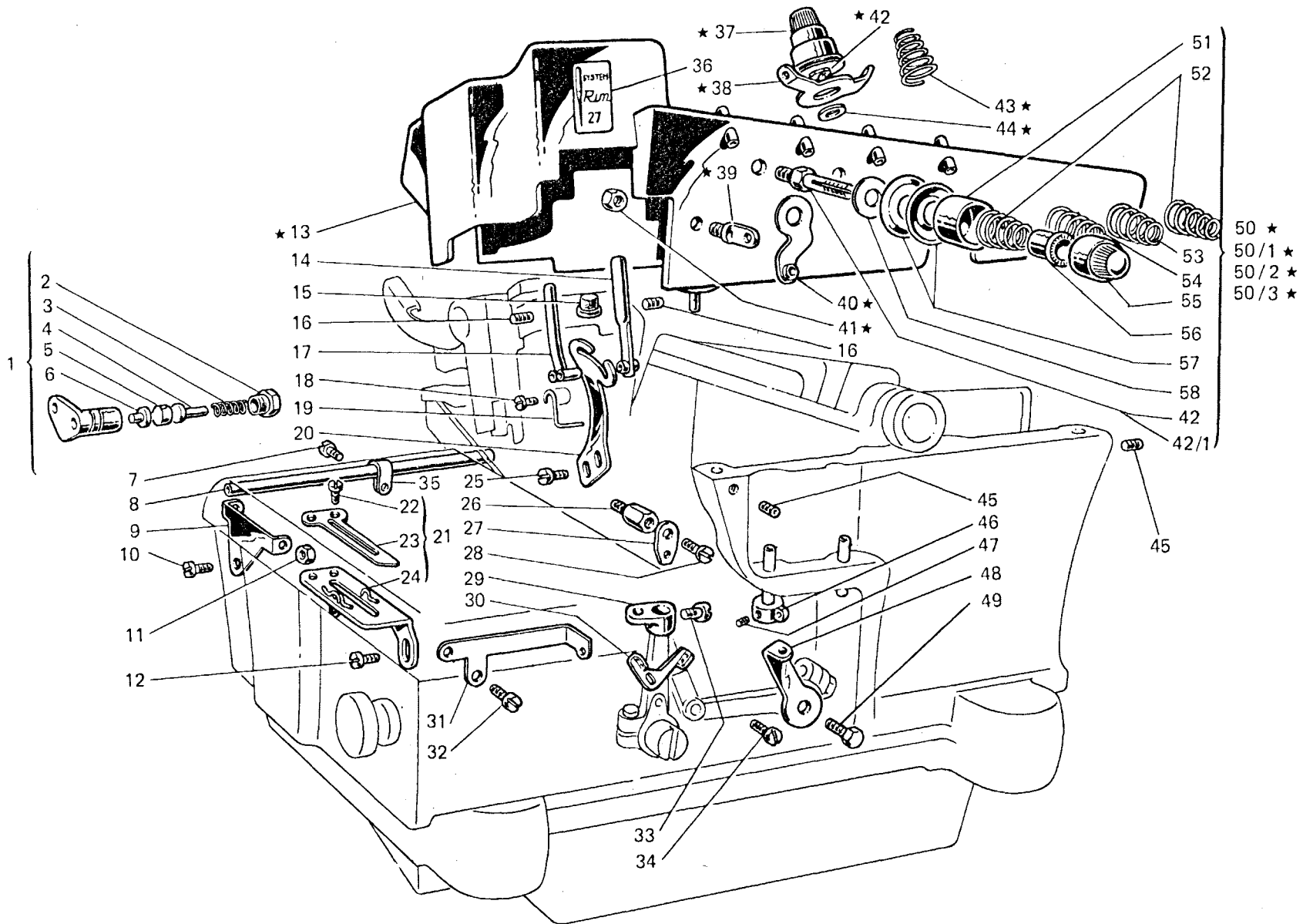

Fig. N. Abb. N.	Part. N. Bestell N. Piece N. Pieza N.	Qt. Anzahl	DESCRIZIONE	DESCRIPTION	BENENNUNG	DESCRIPTION	DESCRIPCION
★	206257-4-00	1	coperchio superiore completo	upper cover assembly			
1	204748-4-11	1	passafilo completo dell'ago	thread guide assembly			
2	202260-0-10	1	tappo filettato	plug			
3	202257-0-10	1	molla	spring			
4	202258-0-10	1	pernetto	pin			
5	203635-0-10	1	pastiglia	plug			
6	202256-0-10	1	pernetto	pin			
7	741559-2-00	1	vite	screw			
8	204704-0-10	1	tubetto	tube			
9	204747-0-10	1	passafilo	thread guide			
10	724422-2-00	1	vite	screw			
11	733505-2-00	1	dado	nut			
12	721424-2-00	2	vite	screw			
13	206317-3-00	1	coperchio con passafili	cover with thread guide			
14	206714-2-00	1	passafilo	thread guide			
15	206746-0-00	1	tampone	pad			
16	729011-2-00	2	vite	screw			
17	203647-2-11	1	passafilo dell'ago	needle thread guide			
18	741535-0-00	1	vite	screw			
19	204753-0-10	1	cavallotto guida fili	coupling			
20	206535-0-00	1	tendifilo dell'ago	needle thread guide			
21	204760-4-10	1	mensola completa	bracket assembly			
22	701405-0-00	2	vite	screw			
23	204761-0-10	1	mensola premi filo	bracket			
24	204759-2-10	1	mensola con spine	bracket with pin			
25	741539-0-00	2	vite	screw			
26	206755-0-00	1	colonnina per passafilo	column			
27	206812-0-00	1	passafilo crochet inferiore	upper looper thread guide			
28	744631-2-00	1	vite	screw			
29	204750-0-10	1	squadretta	bracket			
30	204911-0-11	1	tendifilo	thread guide			
31	206876-0-00	1	passafilo	thread guide			
32	741682-0-00	1	vite	screw			
33	741400-0-00	1	vite	screw			
34	741657-0-00	1	vite	screw			
35	204756-0-10	1	fascetta	collar			
36	788001-0-01	1	decalcomania sist.aghi RIM 27	needle Rim 27 decalcomania			
37	206340-4-00	1	tensione compl.con molla fig.43	tension assembly with spring fig.43			
38	203630-0-10	1	passafilo	thread guide			
39	206711-0-00	3	passafilo	thread guide			
40	206713-2-00	1	passafilo	thread guide			
41	733503-0-00	3	dado	nut			
42	202225-0-10	2	perno per tensione fig.50-37	pin for tension fig.50-37			
42/1	206747-0-01	3	perno per ten,fig.50/1-50/2-50/3	pin for tension fig.50/1-50/2-50/3			
43	203457-0-10	1	molla per tensione fig.50/1	spring for tension fig.50/1			
44	705013-0-00	1	rondella	washer			
45	745803-2-00	3	vite	screw			

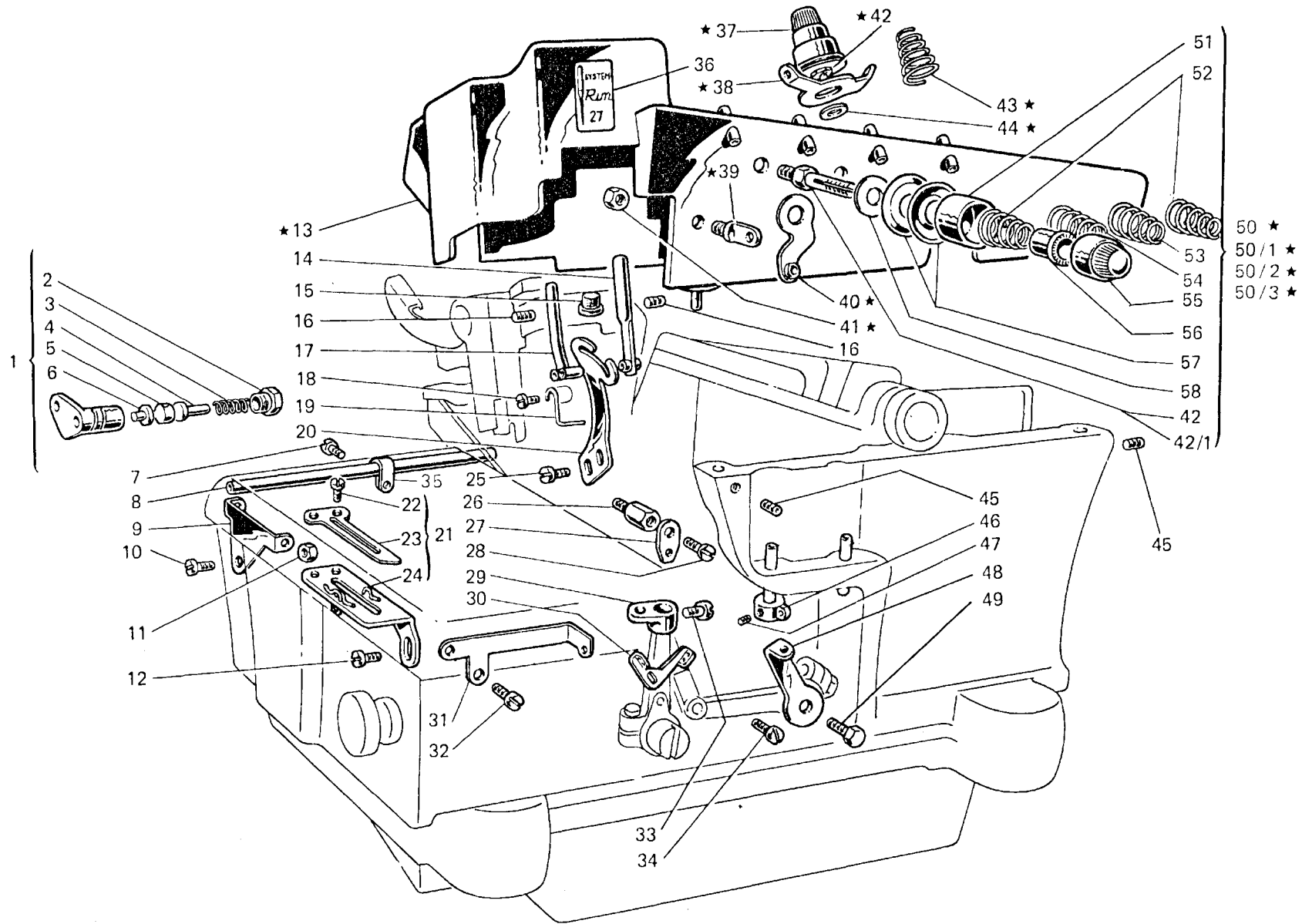

Fig. N. Abb. N.	Part. N. Bestell N. Pieza N.	Qt. Anzahl	DESCRIZIONE	DESCRIPTION	BENENNUNG	DESCRIPTION	DESCRIPCION
46	202282-0-10	1	tendifilo	thread guide			
47	745002-0-00	1	vite	screw			
48	202683-0-10	1	tendifilo crochet infer.	thread guide lower looper			
49	720431-2-00	1	vite	screw			
50	206346-4-00	1	tensione completa con molla fig.52	tension assembly for spring fig.52			
50/1	206342-4-00	1	tensione compl.con molla fig. 54	tension assembly for spring fig. 54			
50/2	206343-4-00	1	tensione completa con molla fig.53	tension assembly for spring fig. 53			
50/3	206341-4-00	1	tensione completa con molla fig.52	tension assembly for spring fig.52			
51	202556-0-00	5	scodellino	cap			
52	202227-0-10	2	molla per tensione fig.50-50/3	spring for tension fig.50-50/3			
53	202681-0-10	1	molla per tensione fig.50/2	spring for tension fig.50/2			
54	202228-0-10	1	molla per tensione fig.50/1	spring for tension fig.50/1			
55	202558-2-00	5	pomolo	knob			
56	202229-0-10	5	bussola	bush			
57	300218-0-10	10	disco per tensione	tension disc			
58	206754-0-00	5	rondella	washer			

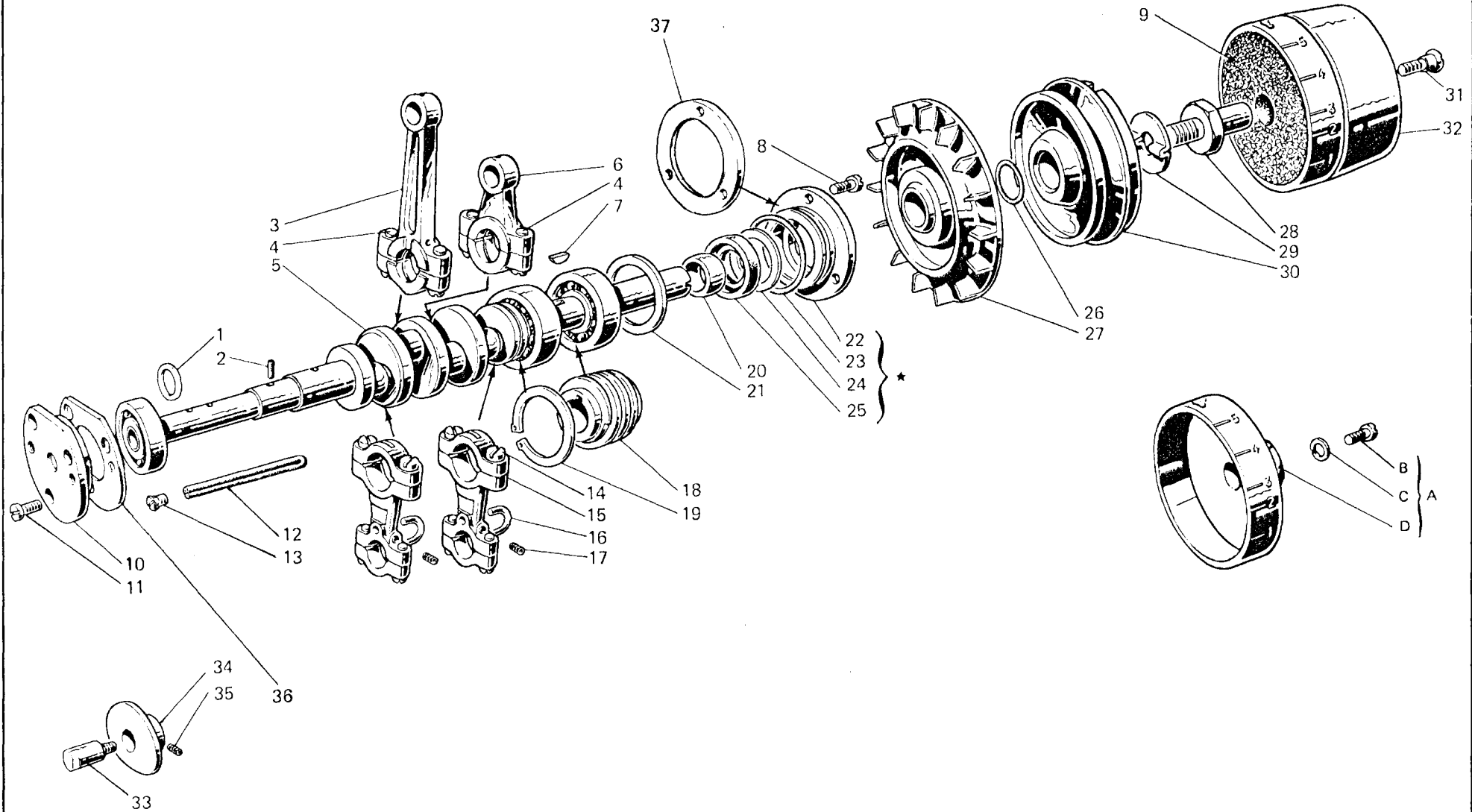

Fig. N. Abb. N.	Part. N. Bestell N. Piece N. Pieza N.	Ct. Anzahl	DESCRIZIONE	DESCRIPTION	BENENNUNG	DESCRIPTION	DESCRIPCION
★	206697-4-01	1	gruppo flangia con anelli	flange with ring			
1	206532-0-00	1	rondella	washer			
2	206708-0-00	1	stoppino	wick			
3	206549-2-00	1	biella albero sup.con vite	connecting rod with screw			
4	743471-2-00	4	vite	screw			
5	206705-3-00	1	albero principale con cuscinetti	main shaft with bearings			
6	206578-2-00	1	biella comando alb.coltello sup.	connecting rod for upper knife			
7	204122-0-10	1	chiavetta	key			
8	721464-2-00	3	vite	screw			
9	206507-0-00	1	tampone per volantino	pad			
10	206860-0-00	1	flangia sinistra	left flange			
11	741956-2-00	3	vite	screw			
12	778406-0-00	1	stoppino	wick			
13	206681-0-00	1	tappo	plug			
14	743243-2-00	8	vite	screw			
15	202071-2-10	2	biella con viti	connecting rod with screw			
16	206643-0-00	2	cavallotto per manicotto	coupling			
17	745800-2-00	2	vite	screw			
18	206556-0-00	1	vite senza fine	worm screw			
19	202386-0-10	1	anello elastico	spring ring			
20	206692-0-00	1	distanziale alb. principale	spacer			
21	206689-0-00	1	anello compensazione	ring			
22	206699-0-00	1	flangia	flange			
23	701133-0-00	1	anello di tenuta	retainer ring			
24	206693-0-00	1	rondella	washer			
25	700630-0-00	1	anello di tenuta	retainer ring			
26	701116-0-00	1	anello di tenuta	retainer ring			
27	206690-2-00	1	ventola di raffreddamento	cooling fan			
28	206683-0-00	1	perno per volantino	pin			
29	206684-0-00	1	chiavetta alb.princ.	key			
30	206508-0-00	1	volantino	pulley			
31	202492-0-10	1	vite	screw			
32	206679-0-00	1	coperchio volantino	pulley cover			
33	204757-0-11	1	perno porta camma	pin			
34	204803-0-10	1	camma tendifilo	cam thread guide			
35	727203-0-00	2	vite	screw			
36	206543-0-00	1	guarnizione	gasket			
37	206544-0-00	1	guarnizione	gasket			
A	202539-4-00	1	<u>SOLO A RICHIESTA</u> coperchio volantino per Quick Stop	<u>ONLY ON REQUEST</u> pulley cover for Quick Stop			
B	721525-0-00	1	vite	screw			
C	703007-0-00	1	rondella	washer			
D	202352-2-11	1	coperchio	cover			

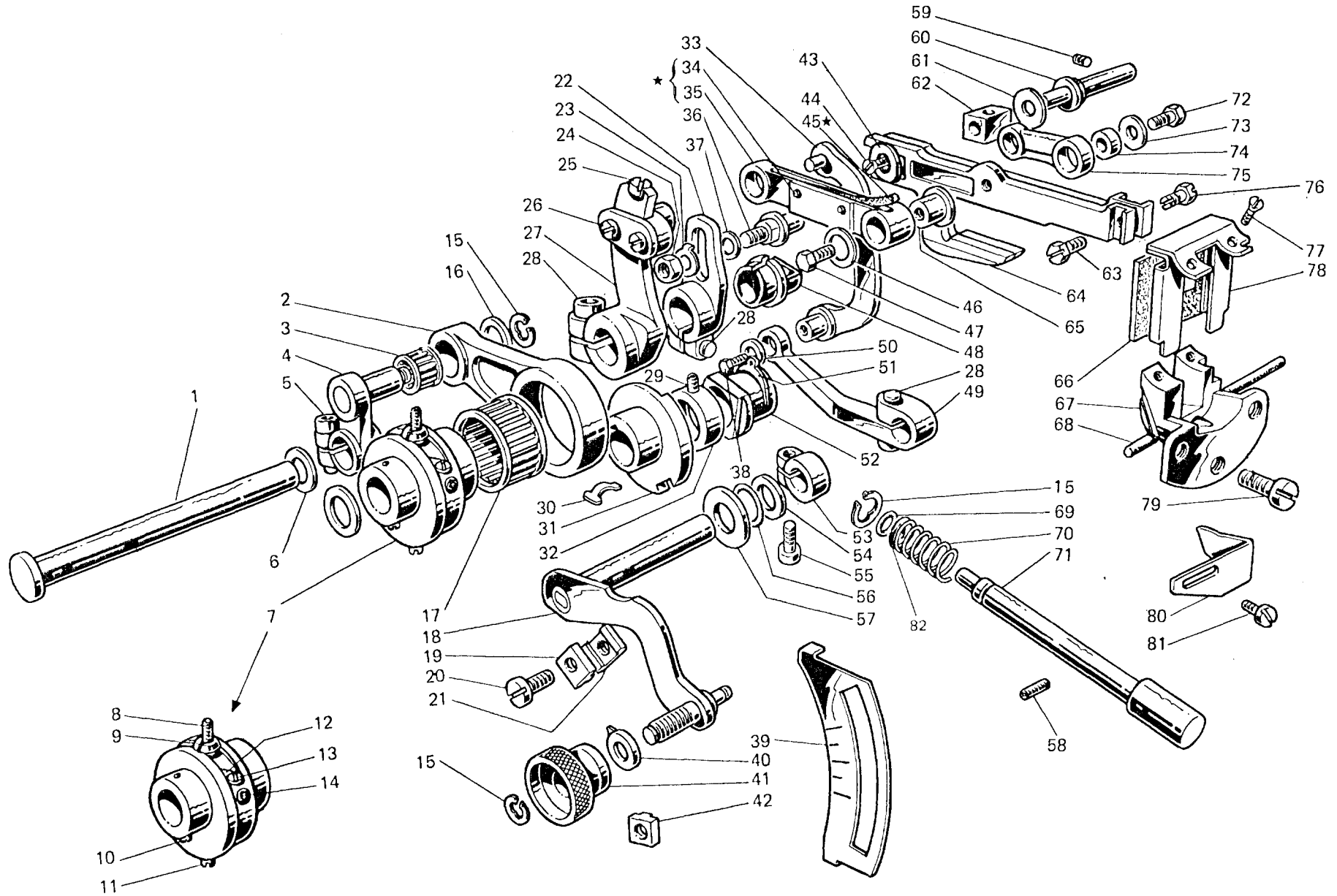

Fig. N. Abb. N.	Part. N. Bestell N. Pieca N. Pieza N.	Qt. Anzahl	DESCRIZIONE	DESCRIPTION	BENENNUNG	DESCRIPTION	DESCRIPCION
★	206615-4-00	1	biellino compl.(figg.34-35-45)	connecting rod assembly			
1	206593-0-00	1	contralbero trasporto	transport countershaft			
2	206599-0-00	1	biella comando trasporto	transport connecting rod control			
3	201358-0-10	1	gabbia a rulli	needle cage			
4	206598-3-00	1	braccio a manovella con vite	connecting-rod with screw			
5	744334-2-00	1	vite	screw			
6	704841-0-00	1	rondella	washer			
7	206871-4-01	1	gruppo ecc.regol.trasporto	eccentric group			
8	729051-2-00	1	vite	screw			
9	206603-0-10	1	fermo eccentrico	eccentric retainer			
10	745125-2-00	1	vite	screw			
11	728272-0-00	1	vite	screw			
12	202412-0-10	1	lardone	gib			
13	202473-0-10	2	vite	screw			
14	202472-0-10	2	vite	screw			
15	700207-0-00	3	anello elastico	spring ring			
16	206546-0-00	1	rondella	washer			
17	202385-0-10	1	gabbia a rulli	needle cage			
18	206790-2-00	1	leva comando slitta	lever			
19	206799-0-00	1	arresto regolabile esterno	external retainer			
20	742222-2-00	2	vite	screw			
21	206795-0-00	2	arresto regolabile interno	internal retainer			
22	206584-2-00	1	braccio manovella	connecting rod			
23	206580-2-00	1	rondella con spina	washer with pin			
24	746008-0-00	1	dado	nut			
25	741413-0-00	1	vite	screw			
26	741546-2-00	2	vite	screw			
27	206592-3-00	1	manovella trasporto	transport crank			
28	744332-2-00	3	vite	screw			
29	745812-2-00	1	vite	screw			
30	206872-0-00	1	molla	spring			
31	206605-0-01	1	eccentrico	eccentric			
32	206606-2-00	1	anello di rasamento	shim			
33	202047-2-10	1	leva	lever			
34	200490-0-00	2	spillo	pin			
35	206587-0-00	1	biellino	connecting rod			
36	202063-0-10	1	spina	pin			
37	704808-0-00	1	rondella	washer			
38	740220-2-00	1	vite	screw			
39	206797-0-00	1	piastrina per indice	plate			
40	206796-0-00	1	indice rapp.differenziale	differential index			
41	206798-0-00	1	bottone rapp.differenziale	differential button			
42	206794-0-00	1	arresto regolabile esterno	external retainer			
43	202475-0-10	1	rondella	washer			
44	724032-0-00	1	vite	screw			
45	778417-0-00	1	stoppino	wick			
46	705008-0-00	1	rondella	washer			

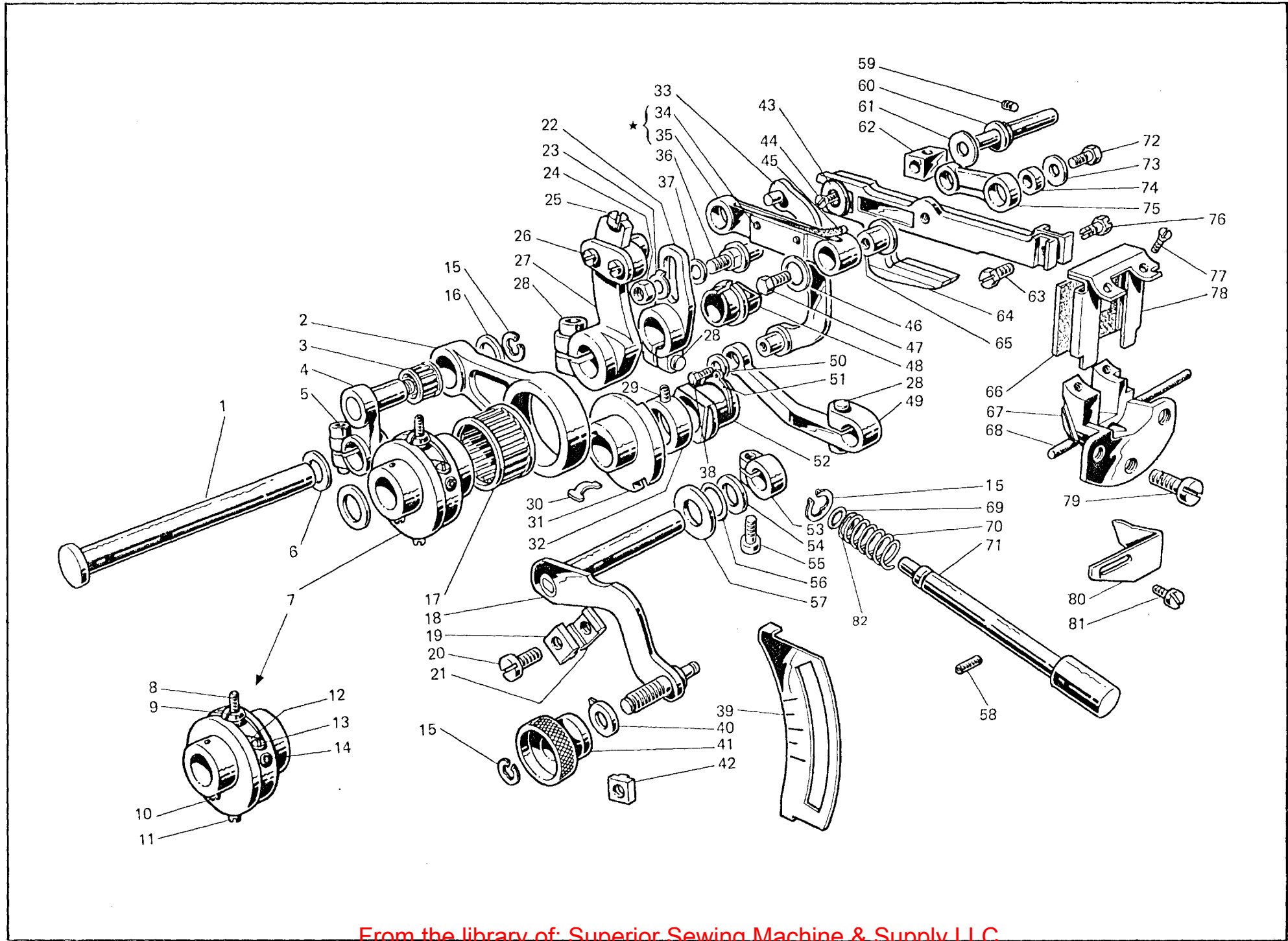

Fig. N. Abb. N.	Part. N. Bestell N. Piece N. Pieza N.	Ct. Anzahl	DESCRIZIONE	DESCRIPTION	BENENNUNG	DESCRIPTION	DESCRIPCION
47	206588-0-00	1	vite	screw			
48	206619-0-00	1	vaschetta-olio	oil sump			
49	206614-2-00	1	braccio regol.differenziale	differential arm			
50	705201-0-00	1	rondella	washer			
51	201610-0-01	1	anello elastico	spring ring			
52	206617-0-00	1	blocchetto	block			
53	100620-0-10	1	morsetto	clamp			
54	704829-0-00	1	rondella	washer			
55	741745-2-00	1	vite	screw			
56	701007-0-00	1	anello di tenuta	retainer ring			
57	705230-0-00	1	rondella	washer			
58	729032-2-00	1	vite	screw			
59	202478-0-10	1	vite	screw			
60	206613-0-00	1	perno eccentrico	eccentric pin			
61	705408-0-00	1	rondella	washer			
62	202033-0-10	1	blocchetto	block			
63	202489-0-10	1	vite	screw			
64	206582-3-00	1	gruppo slitta porta griffe	feed dog slide group			
65	206586-0-00	1	bussola per biellino	bush			
66	206804-0-00	1	raschia olio	oil scraper			
67	206608-0-00	1	guida supporto a slitta	slide support guide			
68	206609-0-00	1	guarnizione guida	gasket			
69	701004-0-00	1	anello	ring			
70	202408-0-10	1	molla	spring			
71	206618-0-10	1	pulsante regola punto	bush-button			
72	202490-0-10	1	vite	screw			
73	705208-0-00	1	rondella	washer			
74	202032-0-10	1	bussolina	bush			
75	206583-0-00	1	biellino	connecting-rod			
76	202488-0-10	1	vite	screw			
77	744621-0-00	2	vite	screw			
78	206803-2-00	1	telaio raschiaolio	oil scraper frame			
79	721464-2-00	3	vite	screw			
80	204905-0-10	1	squadretta protez. griffe	feed dog bracket protection			
81	721443-2-00	1	vite	screw			
82	704314-2-00	1	rondella	washer			

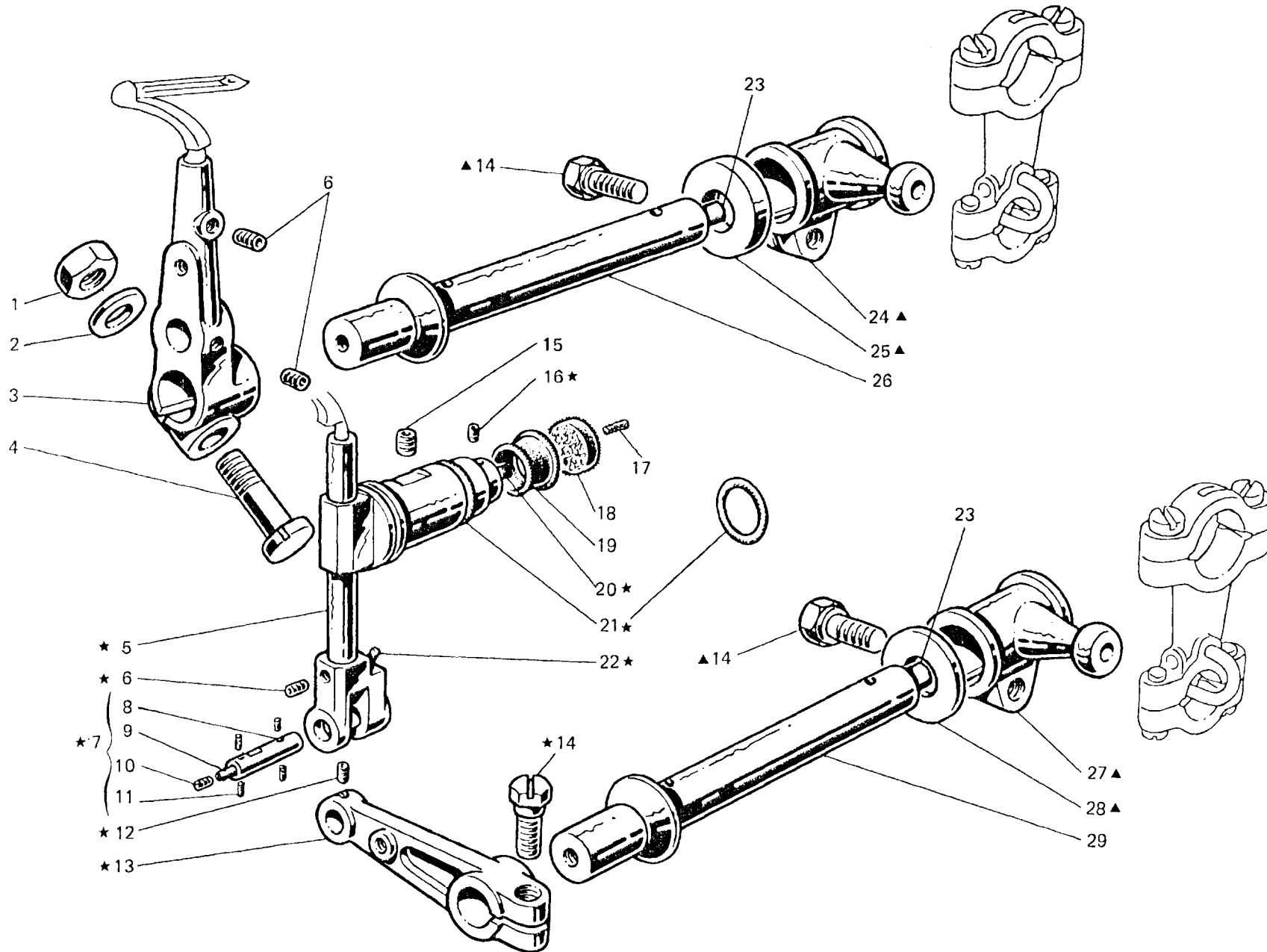

Fig. N. Abb. N.	Part. N. Bestell N. Pieca N. Pieza N.	Qt. Anzahl	DESCRIZIONE	DESCRIPTION	BENENNUNG	DESCRIPTION	DESCRIPCION
▲	206386-4-00	1	gruppo manicotto com. crochet	control looper assembly			
★	206415-4-00	1	gruppo com. crochet superiore	upper looper control			
1	746408-2-00	1	dado	nut			
2	705013-0-00	1	rondella	washer			
3	204671-0-10	1	porta crochet inferiore	lower looper holder			
4	204700-0-10	1	perno a vite	pin			
5	206410-3-00	1	guida oscillante	oscillating guide			
6	745812-2-00	3	vite fissa crochet	screw			
7	206645-4-00	1	spina	pin			
8	202086-0-10	1	spina	pin			
9	778401-0-00	1	stoppino	wick			
10	745002-2-00	1	vite	screw			
11	778202-0-00	4	stoppino	wick			
12	745800-2-00	1	vite	screw			
13	206652-2-00	1	braccio	arm			
14	201128-0-10	3	vite	screw			
15	745168-0-00	1	vite	screw			
16	727002-0-00	2	vite	screw			
17	778236-0-00	1	stoppino	wick			
18	206686-0-00	1	disco lubrif. guida	lubrication disc			
19	202720-0-00	1	paraolio	oil retainer			
20	778417-0-00	1	stoppino	wick			
21	701113-0-00	1	anello di tenuta	retainer ring			
22	778208-0-00	1	stoppino	wick			
23	206695-0-00	2	tappo per albero	plug for shaft			
24	206659-2-00	1	manicotto con vite	coupling with screw			
25	704847-0-00	1	rondella	washer			
26	206656-0-00	1	albero crochet inferiore	lower looper shaft			
27	206658-2-00	1	manicotto	coupling			
28	704845-0-00	1	rondella	washer			
29	206646-0-00	1	albero crochet superiore	upper looper shaft			

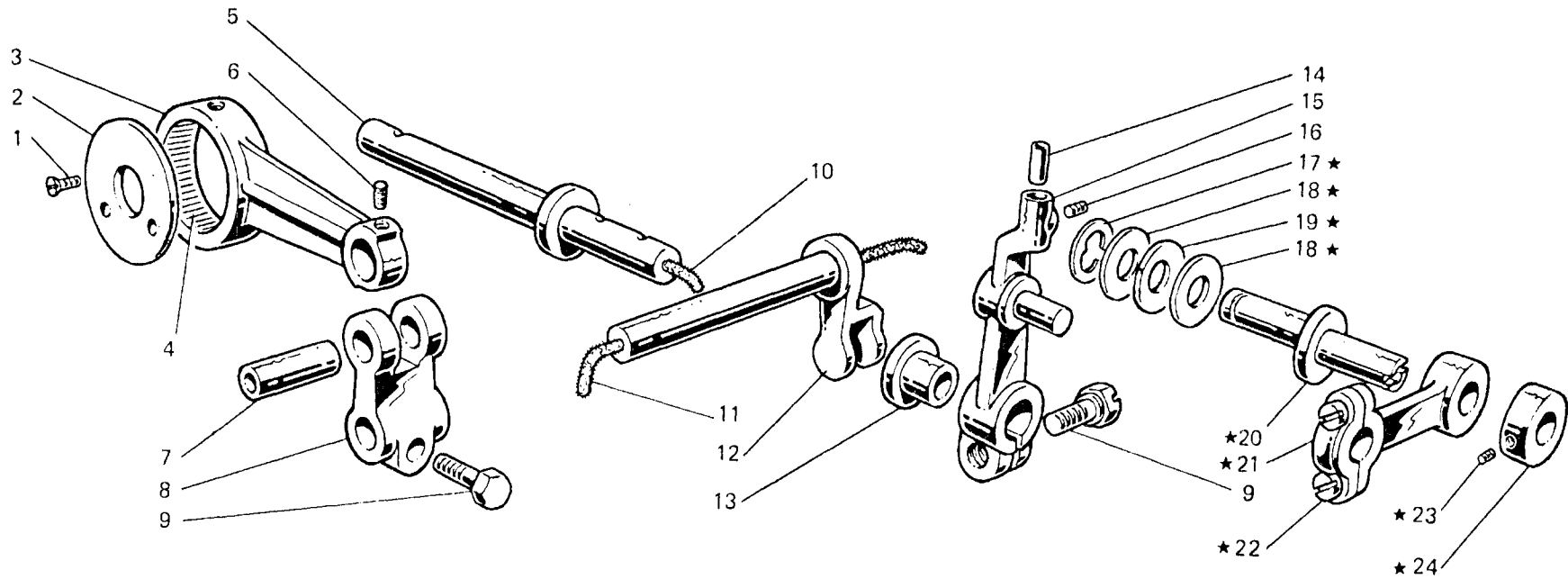

Fig. N. Abb. N.	Part. N. Bestell N. Piece N. Pieza N.	Qt. Anzahl	DESCRIZIONE	DESCRIPTION	BENENNUNG	DESCRIPTION	DESCRIPCION
★	2048554-10	1	gruppo bielle com. rotaz.crochet con fig. 1-2-3-4-6 Tav. 7	looper rotation con-rod assembly			
1	744530-0-00	2	vite	screw			
2	204729-0-10	.1	rondella	washer			
3	204762-0-11	1	biella comando crochet	looper con-rod control			
4	204787-0-10	1	gabbia a rullini	needle cage			
5	204778-3-10	1	alberino con corona	shaft			
6	745124-0-00	1	vite	screw			
7	204659-0-10	1	spina per attacco forcella	pin for attachment fork			
8	204755-2-10	1	attacco a forcella	fork coupling			
9	202487-0-10	2	vite	screw			
10	778421-0-00	1	stoppino	wick			
11	778408-0-00	1	stoppino	wick			
12	204776-0-10	1	perno con forcella	pin with fork			
13	204769-0-10	1	bussola	bush			
14	204912-0-10	1	bussolina distanziale	spacer bush			
15	204674-3-10	1	porta crochet	looper holder			
16	745812-2-00	1	vite per fissaggio crochet	screw			
17	700208-0-00	1	anello elastico	spring ring			
18	704813-0-00	2	rondella	washer			
19	702412-0-00	1	molla a tazza	spring			
20	204913-0-10	1	spina eccentrico	eccentric pin			
21	204764-3-10	1	biella	con-rod			
22	204800-0-10	2	vite	screw			
23	745800-2- 0	2	vite	screw			
24	204773-0-10	1	anello di registro	adjustment ring			

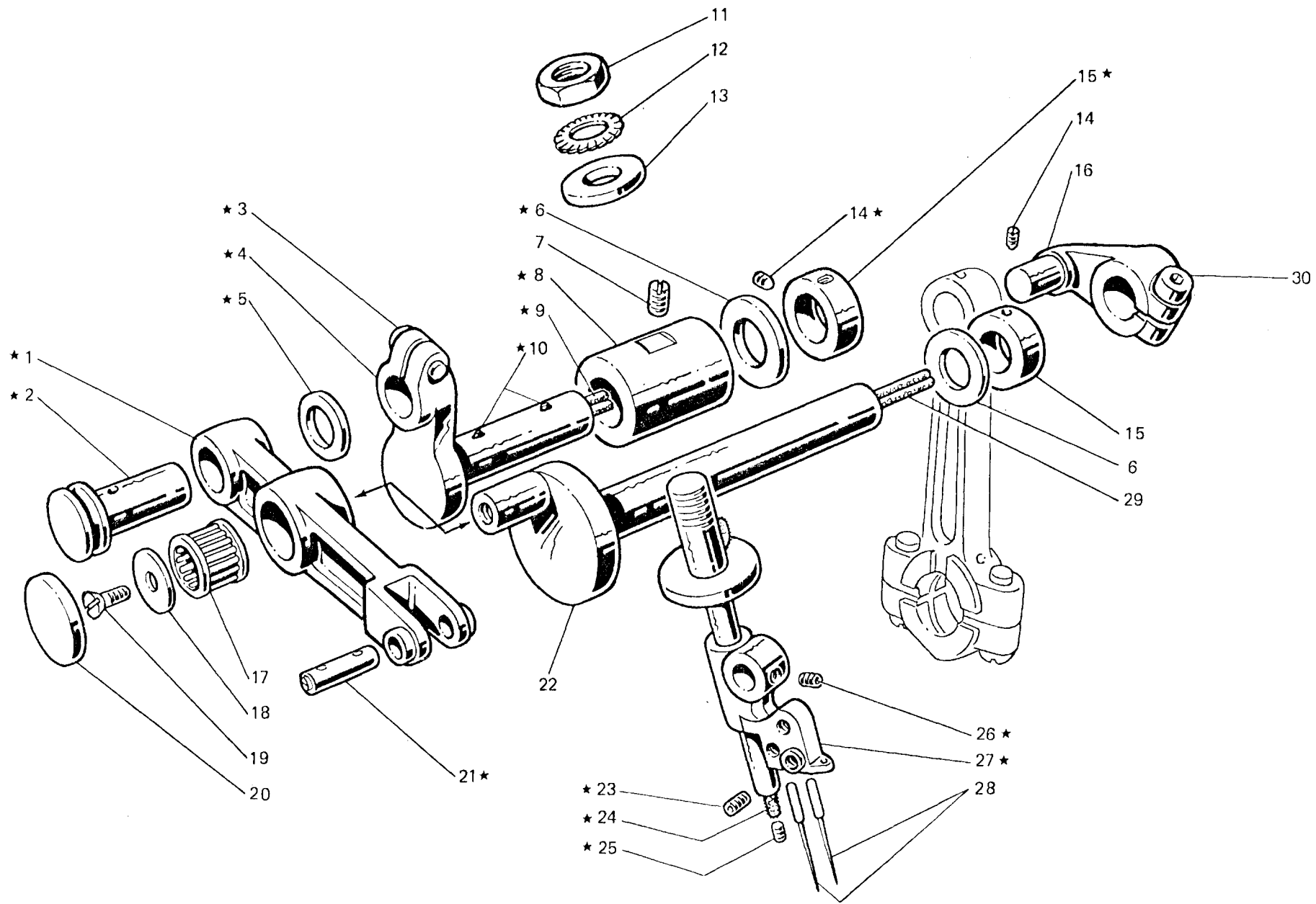

Fig. N. Abb. N.	Part. N. Bestell N. Piece N. Pieza N.	Qt. Anzahl	DESCRIZIONE	DESCRIPTION	BENENNUNG	DESCRIPTION	DESCRIPCION
★	206429-4-00	1	cinematismo com. ago	needle control assembly			
1	206516-0-00	1	leva	lever			
2	206525-3-00	1	perno	pin			
3	744332-2-00	1	vite	screw			
4	206522-3-00	1	albero	shaft			
5	704837-0-00	1	rondella	washer			
6	705029-0-00	2	rondella	washer			
7	727706-0-00	1	vite	screw			
8	206524-0-00	1	bussola	bush			
9	778407-0-00	1	stoppino	wick			
10	778203-0-00	4	stoppino	wick			
11	206506-0-00	1	dado	nut			
12	703210-0-00	1	rondella	washer			
13	206514-0-00	1	rondella	washer			
14	745812-2-00	2	vite	screw			
15	206606-2-00	2	anello	ring			
16	206540-2-00	1	manovella alb.sup.con vite	connecting rod with screw			
17	206518-0-00	1	gabbia rullini	needle cage			
18	206531-0-00	1	rondella	washer			
19	724032-0-00	1	vite	screw			
20	206533-0-00	1	coperchio per leva	cover for lever			
21	206529-4-00	1	spina	pin			
22	206530-4-00	1	albero a manov.con stoppino	shaft with wick			
23	745800-2-00	2	vite	screw			
24	778400-0-00	1	stoppino	wick			
25	745001-0-00	1	vite	screw			
26	745002-0-00	1	vite	screw			
27	206827-4-00	1	barra con mors. fig. 24-25	needle holder with fig.24-25			
28	765200-6-90	2	ago sist.Rim27 fin. 90	needle sist.Rim 27 fin. 90			
29	778837-0-00	1	stoppino	wick			
30	744334-2-00	1	vite	screw			

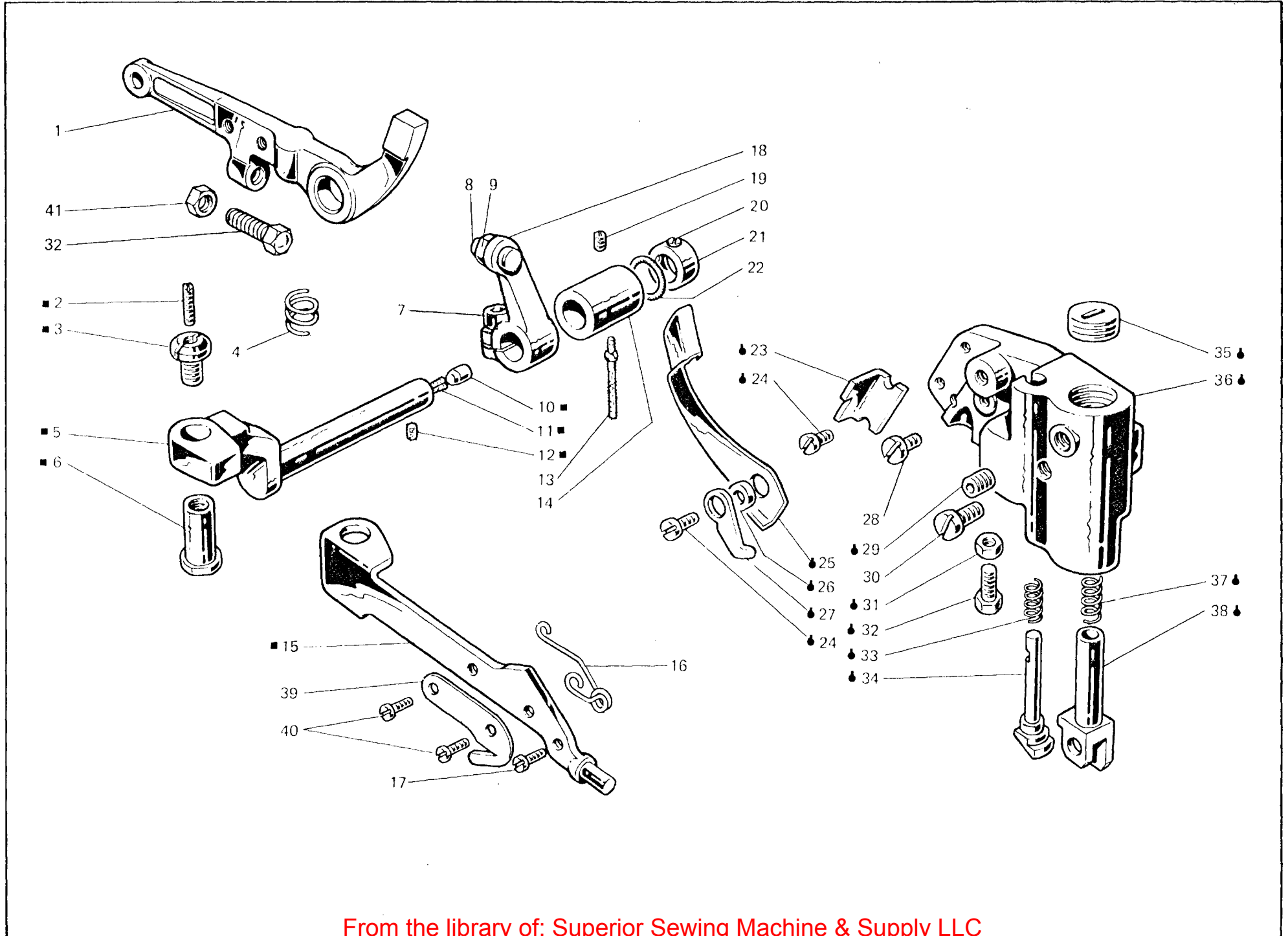

Fig. N. Abb. N.	Part. N. Bestell N. Pieze N. Pieza N.	Qt. Anzahl	DESCRIZIONE	DESCRIPTION	BENENNUNG	DESCRIPTION	DESCRIPCION
♣	206447-4-01	1	gruppo supp.premistoffa	presser support assembly			
■	206638-4-00	1	leva premistoffa con perno (con fig.2-3-5-6-15)	presser lever with pin (with fig. 2-3-5-6-15)			
1	206630-2-01	1	leva alza premistoffa	lever			
2	729051-2-00	1	vite	screw			
3	202529-0-10	1	perno di fermo	pin			
4	206621-0-00	1	molla	spring			
5	206626-3-00	1	perno (con fig.10-11-12)	shaft (with fig.10-11-12)			
6	206622-0-00	1	spina	pin			
7	744332-2-00	1	vite	screw			
8	727096-0-00	1	vite	screw			
9	746020-2-00	1	dado	nut			
10	301586-0-10	1	pastiglia	plug			
11	778520-0-00	1	stoppino	wick			
12	778203-0-00	1	stoppino	wick			
13	206620-0-00	1	stoppino	wick			
14	206629-0-00	1	bussola	bush			
15	206625-0-00	1	leva	lever			
16	204891-0-11	1	molla premipiedino	spring			
17	203187-0-10	1	vite fissa molla	screw			
18	206623-2-11	1	leva arresto premist,con viti	lever with screws			
19	745812-2-00	1	vite	screw			
20	745114-0-00	2	vite	screw			
21	206644-2-00	1	anello con viti	ring with screws			
22	701006-0-00	2	anello di tenuta	retainer ring			
23	206639-0-00	1	arresto	stopping			
24	721464-2-00	3	vite	screw			
25	206636-0-00	1	leva	lever			
26	206637-0-00	1	distanziale	spacer			
27	206635-0-00	1	nasello	snug			
28	721494-2-00	1	vite	screw			
29	202391-0-10	1	vite	screw			
30	206642-0-00	1	vite	screw			
31	746007-2-00	1	dado	nut			
32	202214-0-10	2	vite	screw			
33	202110-0-10	1	molla	spring			
34	206634-0-00	1	tirante	tie-rod			
35	206633-0-00	1	vite	screw			
36	206640-0-00	1	supporto	support			
37	205021-0-10	1	molla	spring			
38	206632-2-00	1	cannotto	column			
39	202194-0-10	1	piastrina taglia catenella	chain cutting sheet			
40	741433-0-00	2	vite	screw			
41	733505-2-00	1	dado	nut			

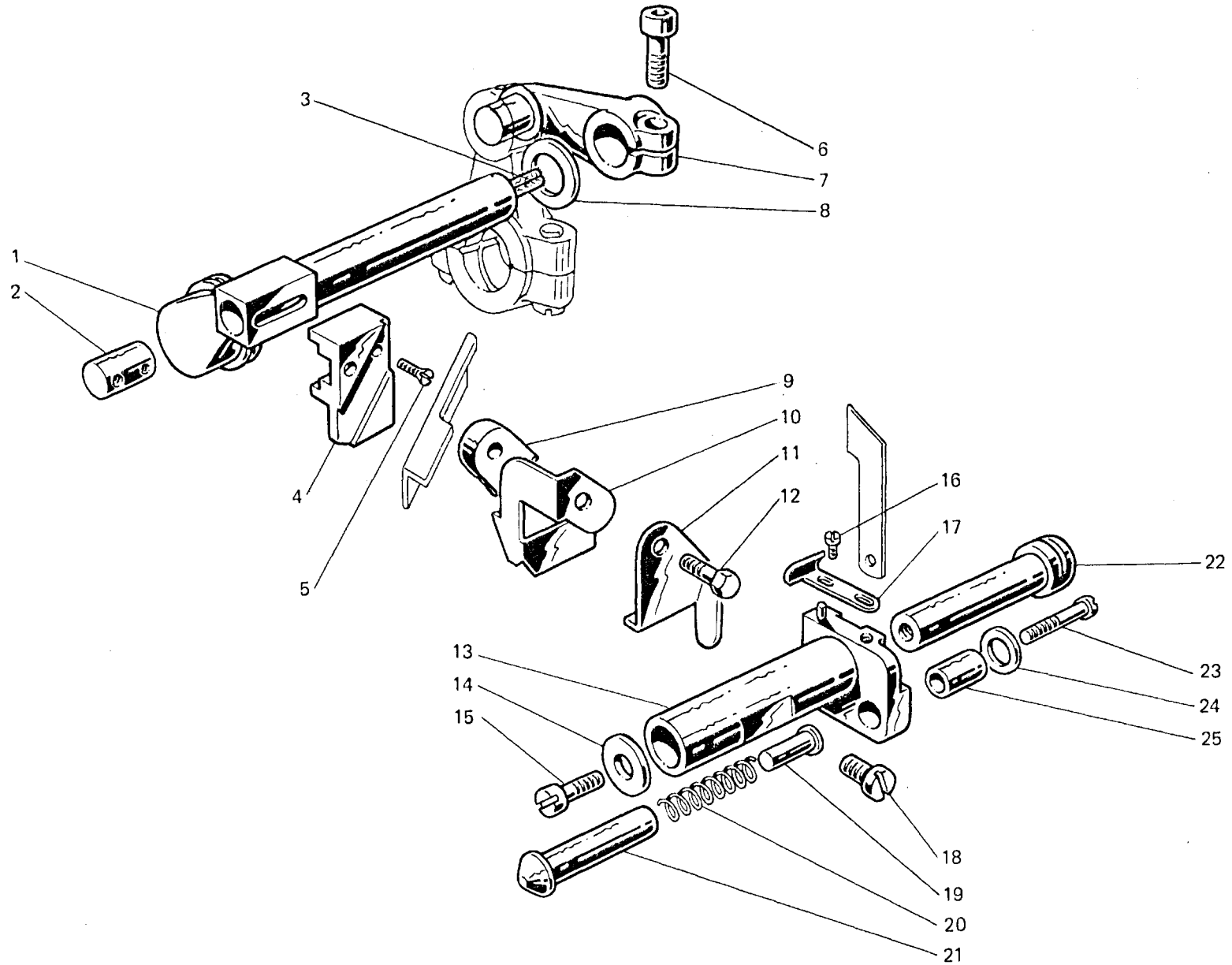

Fig. N. Abb. N.	Part. N. Bestell N. Piece N. Pieza N.	Qt. Anzahl	DESCRIZIONE	DESCRIPTION	BENENNUNG	DESCRIPTION	DESCRIPCION
1	206572-4-00	1	albero colt.sup.con stoppino	upper knife shaft with wick			
2	202130-0-10	1	perno	pin			
3	778832-0-00	1	stoppino	wick			
4	204681-0-10	1	placchetta	plate			
5	744573-0-00	1	vite	screw			
6	744334-2-00	1	vite	screw			
7	206574-2-00	1	manov.alb.colt.sup.	crank for upper knife shaft			
8	705029-0-00	1	rondella	shaft			
9	202131-0-10	1	nasello	snug			
10	204699-0-11	1	carterino	cover			
11	204691-0-10	1	carterino	cover			
12	204799-0-10	1	vite fissa coltello sup.	screw			
13	204685-2-10	1	porta coltello inferiore	lower knife holding			
14	704409-0-00	1	rondella	washer			
15	742457-2-00	1	vite fissa coltello inferiore	screw			
16	741520-0-10	1	vite	screw			
17	204690-0-10	1	spingi asola	front needle guard			
18	742758-0-00	1	vite	screw			
19	206758-0-10	1	puntalino	pin			
20	202128-0-10	1	molla	spring			
21	206757-0-00	1	bussolina	bush			
22	204687-0-10	1	perno	pin			
23	722471-2-00	1	vite	screw			
24	704802-0-00	1	rondella	washer			
25	202129-0-10	1	bussola	bush			

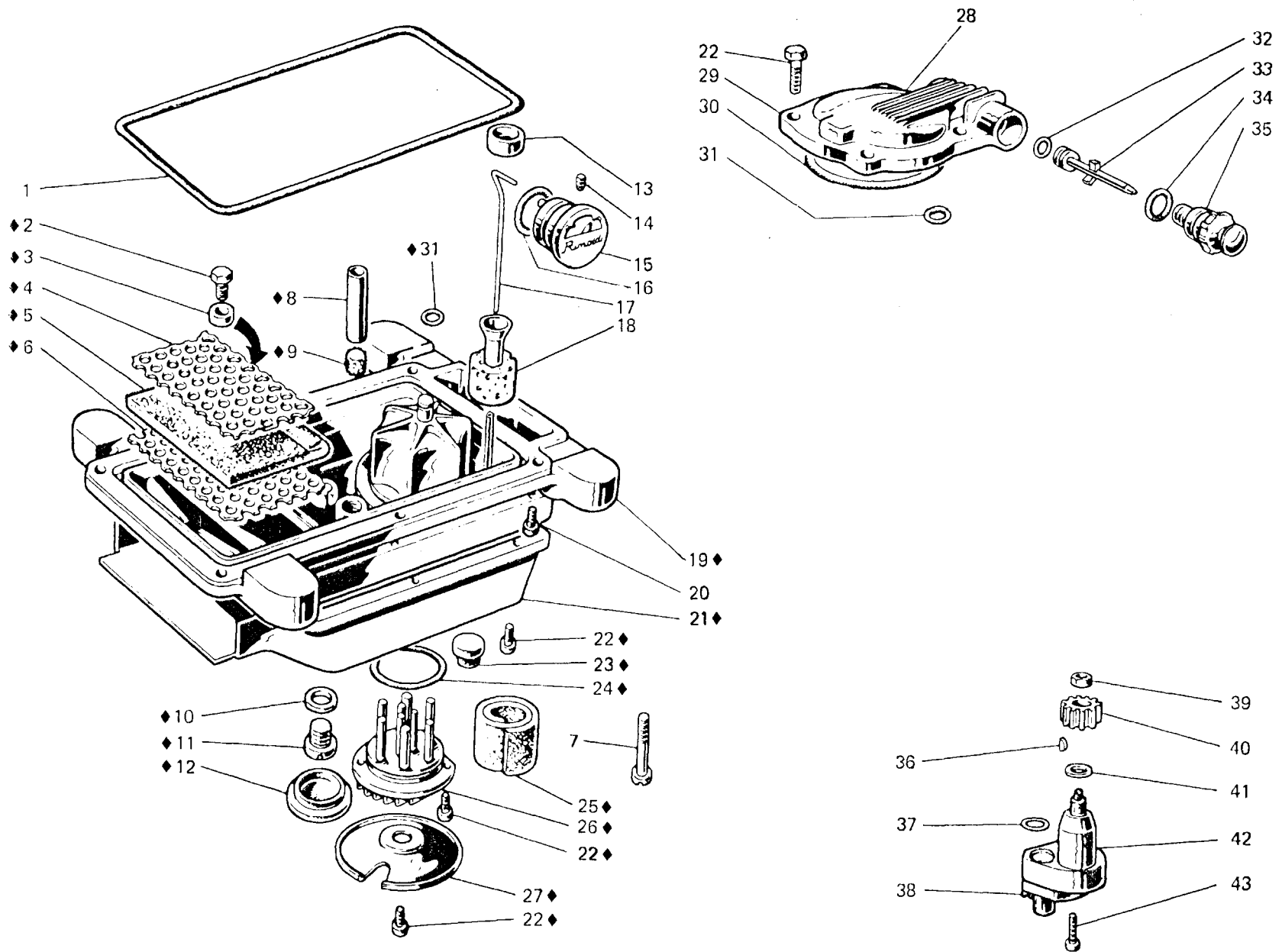

Fig. N. Abb. N.	Part. N. Bestell N. Pieca N. Pieza N.	Qt. Anzahl	DESCRIZIONE	DESCRIPTION	BENENNUNG	DESCRIPTION	DESCRIPCION
◆	206510-4-10	1	bacinella olio compl.	oil sump assembly			
1	206570-0-00	1	guarnizione bacinella	gasket			
2	721484-2-00	1	vite	screw			
3	990335-0-10	1	distanziale	spacer			
4	206567-0-00	1	lamiera forata sup.	upper sheet			
5	206566-0-00	1	filtro	filter			
6	206565-0-00	1	lamiera forata inf.	lower sheet			
7	206642-0-00	1	vite	screw			
8	206568-0-01	1	tubetto	tube			
9	206569-0-00	1	filtro	filter			
10	705977-0-00	1	rondella	washer			
11	206564-0-00	1	tappo	plug			
12	206752-0-00	1	tappo	plug			
13	206667-0-00	1	tappo decompressione	plug			
14	745812-2-00	1	vite	screw			
15	206669-2-01	1	indicatore livello olio	oil level gauge			
16	701032-0-00	1	anello di tenuta	oil ring			
17	206666-0-00	1	astina ind.liv.olio	stick			
18	206665-2-00	1	galleggiante compl.	float			
19	206509-3-10	1	bacinella	oil sump			
20	722442-2-00	6	vite	screw			
21	206750-0-00	1	convogliatore	conveyor			
22	721464-2-00	13	vite	screw			
23	206751-0-00	4	tampone	pad			
24	701051-0-00	1	guarnizione	gasket			
25	206559-0-00	1	filtro	filter			
26	206560-0-10	1	coperchio	cover			
27	206753-0-00	1	coperchio	cover			
28	206742-4-00	1	coperchio distrib.olio	oil distributor cover			
29	206736-2-00	1	coperchio	cover			
30	701151-0-00	1	anello di tenuta	oil ring			
31	701005-0-00	2	anello di tenuta	oil ring			
32	701104-0-00	1	anello di tenuta	oil ring			
33	206743-3-00	1	ugello	nozzle			
34	701113-0-00	1	anello di tenuta	oil ring			
35	206739-0-00	1	spia olio	oil window			
36	206557-0-00	1	chiavetta	key			
37	701004-0-00	1	anello di tenuta	oil ring			
38	721474-2-00	2	vite	screw			
39	733507-0-00	1	dado	nut			
40	206555-0-00	1	ruota	wheel			
41	704813-0-00	1	rondella	washer			
42	206550-4-00	1	gruppo pompa olio	oil pump assembly			
43	722481-2-00	2	vite	screw			

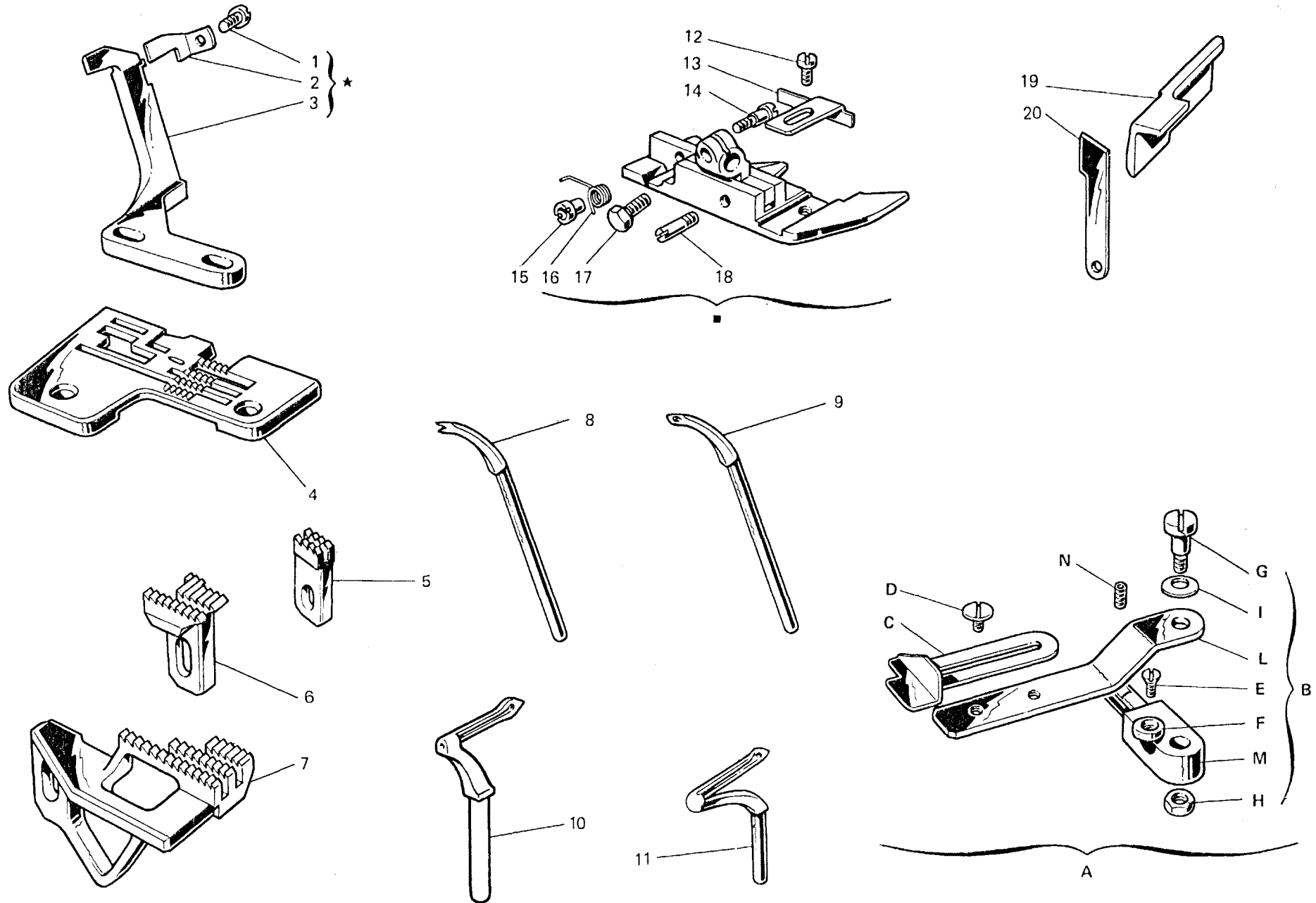
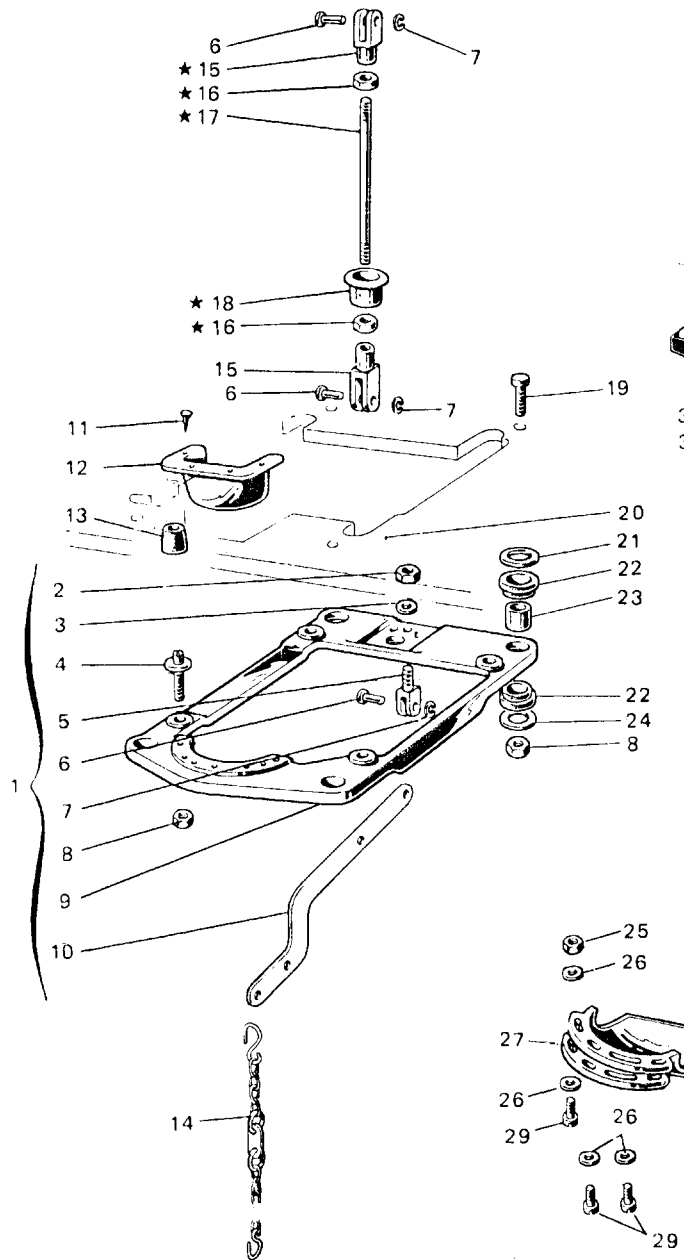

Fig. N. Abb. N.	Part. N. Bestell N. Piece N. Pieza N.	Qt. Anzahl	DESCRIZIONE	DESCRIPTION	BENENNUNG	DESCRIPTION	DESCRIPCION
★	204862-4-10	1	gruppo salva ago e spingi asola	rear and front needle guard assembly			
1	741431-0-00	1	vite	screw			
2	204861-0-10	1	spingi asola	front needle guard			
3	204863-0-10	1	salva ago	rear needle guard			
4	204864-0-10	1	placca ago	needle plate			
5	202609-0-10	1	griffino	feed-dog			
6	204850-0-10	1	griffa sussidiaria	subsidiary feed dog			
7	204846-0-10	1	griffa principale	main feed dog			
8	202092-0-10	1	crochet sup.cieco	upper looper			
9	204033-0-10	1	crochet sup.	upper looper			
10	204675-0-10	1	crochet punto sicurezza	looper			
11	202413-0-11	1	crochet inferiore	lower looper			
12	741413-0-00	1	vite	screw			
13	204878-0-10	1	piastrina	plate			
14	204889-0-10	1	vite	screw			
15	204895-0-10	1	bussola filettata	bush			
16	204894-0-10	1	molla	spring			
17	204947-0-10	1	vite	screw			
18	204869-0-10	1	spina	pin			
19	207003-2-00	1	coltello superiore	upper knife			
20	207020-2-01	1	coltello inferiore	lower knifer			
■	204950-3-11	1	piedino completo	presserfoot assembly			
			SOLO A RICHIESTA	ONLY ON REQUEST			
4	204948-0-10	1	placca ago	needle plate			
6	204851-0-11	1	griffa sussidiaria	subsidiary feed-dog			
	204942-0-10	1	griffa sussidiaria	subsidiary feed-dog			
	204943-0-11	1	griffa sussidiaria	subsidiary feed-dog			
7	204940-0-10	1	griffa principale	main feed-dog			
	204941-0-10	1	griffa principale	main feed dog			
	204997-0-00	1	griffa principale	main feed dog			
10	204676-0-10	1	crochet punto sicurezza	looper			
19	203783-0-10	1	coltello superiore	upper knife			
	203759-0-10	1	coltello superiore	upper knife			
	207004-2-00	1	coltello superiore con placchetta	upper knife			
20	204693-0-11	1	coltello inferiore	lower knife			
A	204919-4-10	1	guida per non tagliare	not cutting guide			
B	202960-4-10	1	guida per non tagliare	not cutting guide			
C	204920-2-10	1	guida	guide			
D	201236-0-10	2	vite	screw			
E	744634-0-00	1	vite	screw			
F	300710-0-10	1	eccentrico	eccentric			
G	743464-2-00	1	vite a collare	screw			
H	746007-2-00	1	dado	nut			
I	702406-0-00	1	molla a tazza	spring			
L	202968-0-10	1	supporto girevole	support			
M	202970-0-10	1	sostegno guida	guide support			
N	729013-2-00	1	vite	screw			

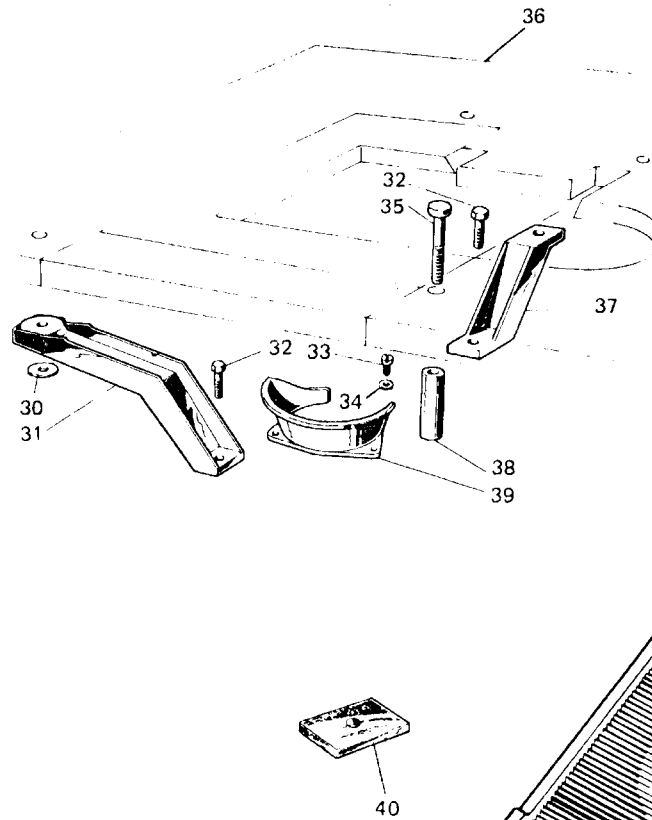

Fig. N. Abb. N.	Part. N. Bestell N. Piece N. Pieza N.	Qt. Anzahl	DESCRIZIONE	DESCRIPTION	BENENNUNG	DESCRIPTION	DESCRIPCION
1	990180-0-10	1	cacciavite grande	screwdriver			
2	990181-0-10	1	cacciavite medio	screwdriver			
3	990327-0-10	1	chiave da 7 mm.	7 mm key			
4	990639-0-10	1	chiave esag. da 3 mm.	hexagonal key			
5	990685-0-10	1	chiave esagonale da 2,5 mm.	hexagonal key			
6	990325-0-10	1	chiave esagonale da 2 mm.	hexagonal key			
7	990474-0-10	1	chiave esagonale da 1,5 mm.	hexagonal key			
8	990183-0-12	1	cuffia protezione testa	machine cover			
9	990622-0-10	1	chiave poligonale da 9 mm.	9 mm. key			
10	990577-0-10	1	astina Infilatura	threading rod			
11	990182-0-10	1	cacciavite piccolo	screwdriver			
12	990324-0-10	1	chiave a tubo da 7 mm.	7 mm key			
13	990585-0-10	1	chiave fissa da 4-5 mm.	4-5 mm key			
14	990174-0-10	1	chiave da 7-9 mm.	7-9 mm key			
15	990176-0-10	1	pinza per infilatura	threading tweezers			
16	990074-1-11	1	lattina olio da 1 Kg.	oil container			
17	765200-6-11	10	aghi sist.Rim27 fin 110	needle Rim 27 fin 110			
18	990985-0-00	1	imbuto	oil funnel			

PIAZZAMENTO NORMALE
NORMAL SETTING



PIAZZAMENTO INCASSATO
SUBMERGED SETTING



PER PIAZZAMENTO CON MOTORE QUICK STOP TIPO D
FOR SETTING WITH QUICK STOP ENGINE TYPE D

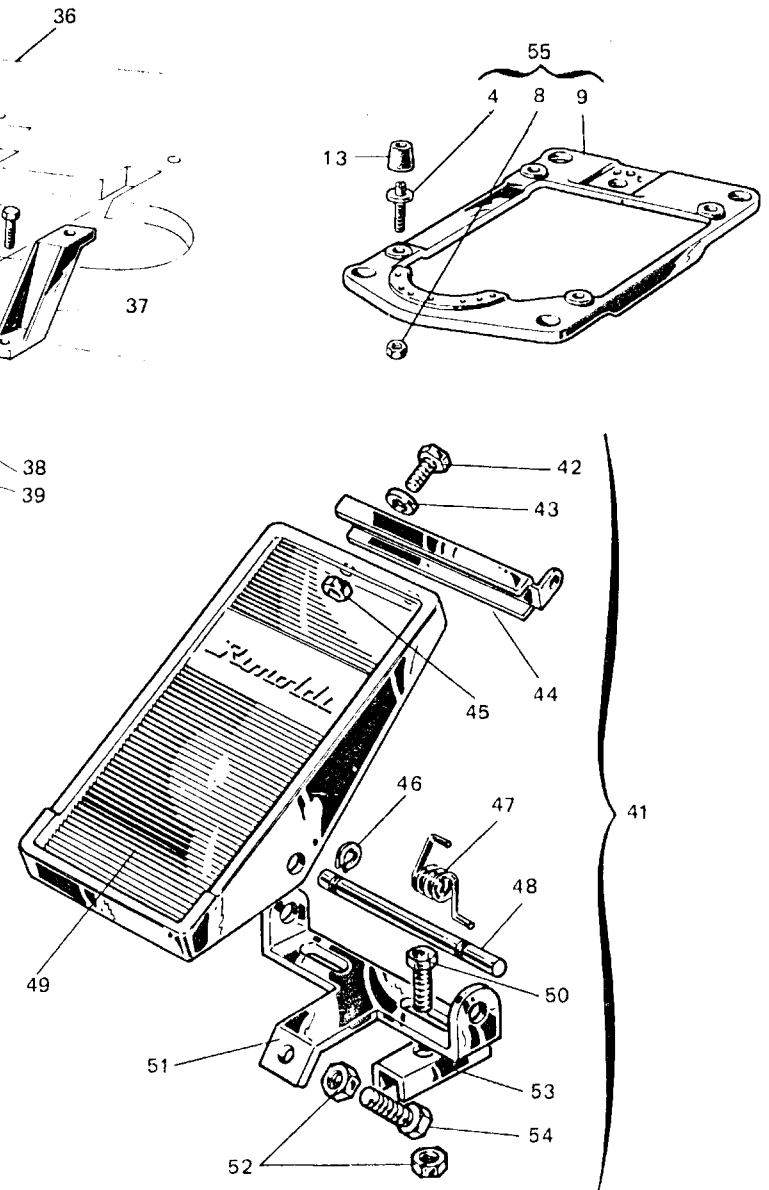
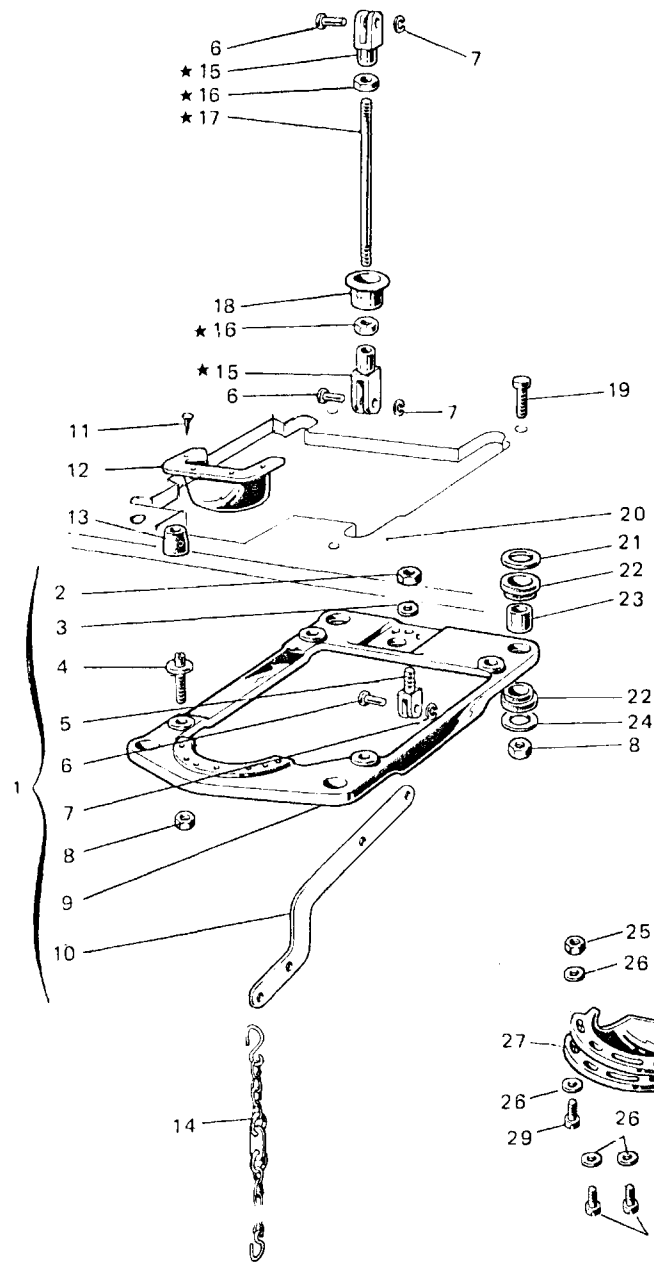
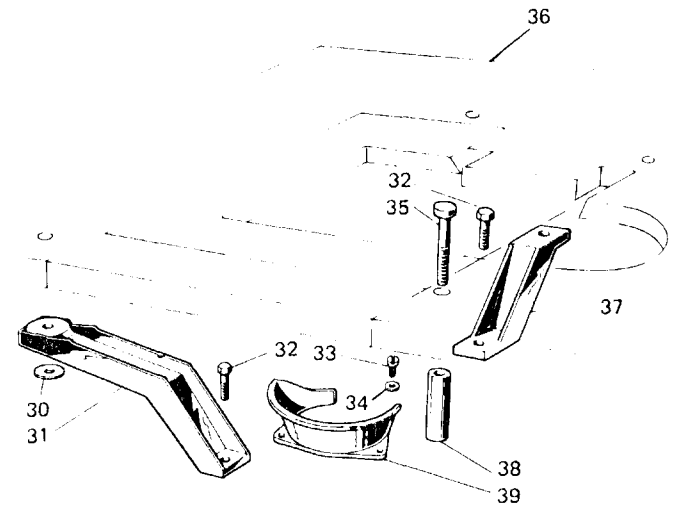

Fig. N. Abb. N.	Part. N. Bestell N. Piece N. Pieza N.	Qt. Anzahl	DESCRIZIONE	DESCRIPTION	BENENNUNG	DESCRIPTION	DESCRIPCION
★	990984-4-00	1	PIAZZAMENTO NORMALE	NORMAL SETTING			
1	990986-4-00	1	tirante alza piedino	rod			
2	746409-2-00	1	supporto testa completo	head support assembly			
3	704424-2-00	1	dado	nut			
4	900694-0-11	4	rondella	washer			
5	990314-0-00	1	perno	pin			
6	990311-0-10	3	supportino per leva	support			
7	700205-0-00	3	perno	pin			
8	733008-2-00	8	anello elastico	spring ring			
9	990981-0-00	1	dado	nut			
10	990316-0-10	1	piastra supporto testa	support plate			
11	990201-0-10	4	leva comando alza piedino	lever			
12	991187-0-00	4	chiodino	rivet			
13	990982-0-00	1	bocchetta scarica ritagli	offlet			
14	990982-0-00	4	ammortizzatore	shock absorber			
15	990179-4-11	1	catenella	chain			
16	990310-0-10	2	giunto	joint			
17	746402-0-00	2	dado	nut			
18	990983-0-00	1	tirante	rod			
19	900204-0-10	1	bussola	bush			
20	722905-2-00	4	vite	screw			
21	901120-2-00	1	tavola	table			
22	704346-2-00	4	rondella	washer			
23	901101-0-00	8	ammortizzatore	shock absorber			
24	901102-0-00	4	bussola	bush			
25	704345-2-00	4	rondella	washer			
55	990987-4-00	1	supporto testa completo solo per motore Quick Stop-tipo D	head support assembly-only for Quick Stop (type D) engine			
			VARIANTE PER PIAZZAMENTO INCASSATO	VARIATION FOR SUBMERGED SETTING			
30	704536-0-00	2	rondella	washer			
31	901105-0-00	1	staffa laterale	bracket			
32	720566-2-00	2	vite	screw			
33	721475-2-00	2	vite	screw			
34	704409-2-00	2	rondella	washer			
35	722917-2-00	2	vite	screw			
36	901123-4-00	1	tavola	table			
37	901104-0-00	1	staffa posteriore	rear bracket			
38	901103-0-00	2	distanziale	spacer			
39	991188-0-00	1	bocchetta scarica ritagli	offlet			

PIAZZAMENTO NORMALE
NORMAL SETTING



PIAZZAMENTO INCASSATO
SUBMERGED SETTING



PER PIAZZAMENTO CON MOTORE QUICK STOP TIPO D
FOR SETTING WITH QUICK STOP ENGINE TYPE D

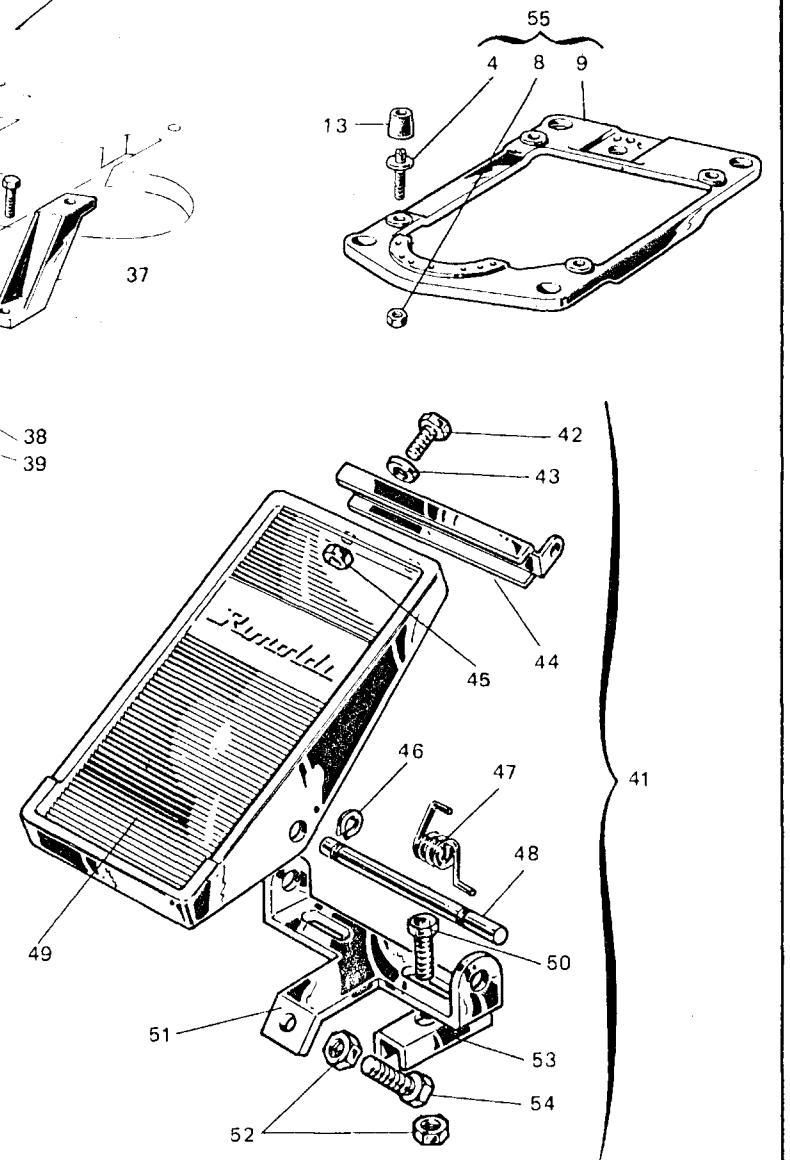

Fig. N. Abb. N.	Part. N. Bestell N. Piece N. Pieza N.	Qt. Anzahl	DESCRIZIONE	DESCRIPTION	BENENNUNG	DESCRIPTION	DESCRIPCION
			PARTICOLARI COMUNI	PARTS FOR BOTH SETTINGS			
25	733507-2-00	1	dado	nut			
26	704409-2-00	4	rondella	washer			
27	991189-0-00	1	piastra rinforzo	plate			
28	991186-0-00	1	canale scarica ritagli	offlet			
29	742068-2-00	3	vite	screw			
40	900203-0-10	4	ammortizzatore per tavola	shock absorber			
41	900925-4-01	1	pedalina completa	pedal assembly			
42	720464-4-00	2	vite	screw			
43	704009-4-00	2	rondella	washer			
44	900926-0-00	1	attacco	attachment			
45	733508-4-00	2	dado	nut			
46	900918-0-00	2	anello elastico	spring ring			
47	900927-0-00	1	molla	spring			
48	900928-0-00	1	perno	pin			
49	900931-0-00	1	copertura	cover			
50	720505-4-00	2	vite	screw			
51	900920-0-00	2	piastrina	plate			
52	720545-4-00	1	vite	screw			
53	733510-4-00	3	dado	nut			
54	900929-0-01	1	supporto	support			

Fig. N. Abb. N.	Part. N. Bestell N. Piece N. Pieza N.	Qt. Anzahl	DESCRIZIONE	DESCRIPTION	BENENNUNG	DESCRIPTION	DESCRIPCION
★	920245-4-00	1	ginocchiello completo (piazzamento normale)	knee-press assembly (normal setting)			
■	920246-4-00	1	ginocchiello completo (piazzamento incassato)	knee-press assembly (submerged setting)			
1	733008-2-00	2	dado	nut			
2	920231-0-00	2	bussola	bush			
3	202395-0-10	2	anello	ring			
4	727024-0-00	4	vite	screw			
5	920230-0-00	1	albero	shaft			
6	920241-0-00	1	supporto	support			
7	920235-0-00	1	molla (piazz.normale)	spring(normal setting)			
	920106-0-10	1	molla (piazz.incassato)	spring(submerged setting)			
8	920128-0-00	1	ancora	anchoring			
9	740035-0-00	9	vite	screw			
10	700206-0-00	2	anello elastico	spring ring			
11	920114-0-10	1	anello	ring			
12	920113-0-10	1	cuscinio	pad			
13	920105-0-10	1	disco	disc			
14	920236-0-00	1	tirante(piazz.normale)	tie rod (normal setting)			
	920237-0-00	1	tirante (piazz.incassato)	tie rod (submerged setting)			
15	920232-2-00	1	leva	lever			
16	920103-0-10	1	attacco	coupling			
17	920490-0-10	1	asta	tie bar			

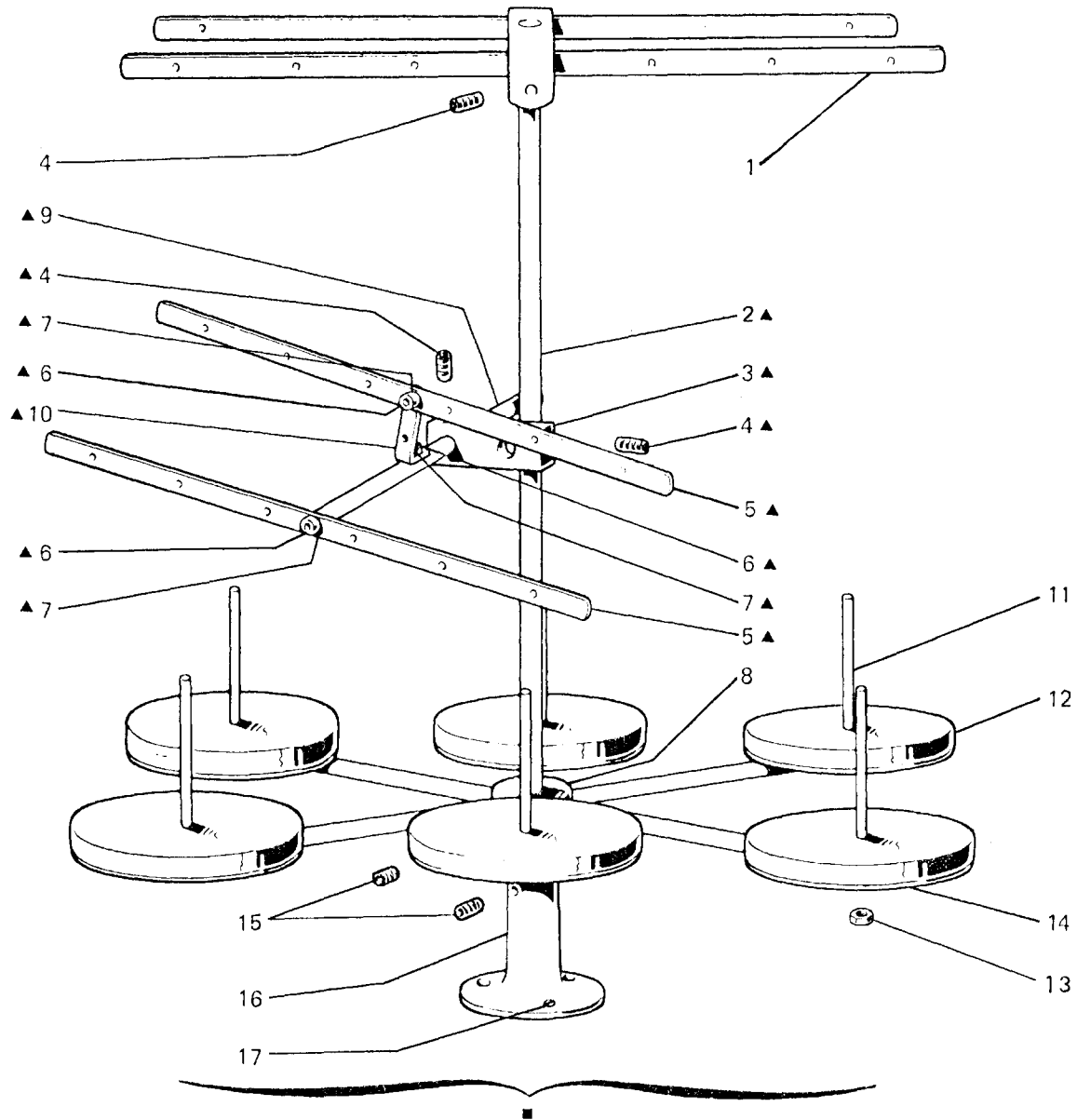

Fig. N. Abb. N.	Part. N. Bestell N. Piezo N. Pieza N.	Qt. Anzahl	DESCRIZIONE	DESCRIPTION	BENENNUNG	DESCRIPTION	DESCRIPCION
1	991140-2-00	1	telaietto	frame			
2	991113-0-00	1	asta principale	main rod			
3	991128-0-00	1	blocchetto	block			
4	729034-2-00	3	vite	screw			
5	991137-2-00	2	telaietto con bussole	frame with bush			
6	722431-2-00	3	vite	screw			
7	703005-0-00	3	rondella	washer			
8	991144-3-00	1	mozzo con aste	hub with pins			
9	991106-0-00	1	asta	rod			
10	991107-0-00	1	squadretta	bracket			
11	991111-0-00	6	astina	rod			
12	991179-0-00	6	disco antivibrante	disc			
13	733508-2-00	12	dado	nut			
14	991112-0-00	6	piatto	plate			
15	729054-2-00	3	vite	screw			
16	991114-0-00	1	basetta	base			
17	731107-0-00	3	vite a legno	screw			
■	991135-6-00	1	gruppo porta bobine a 6 posti	bobbin carrier assembly			
▲	991136-4-00	1	telaietto supplementare completo	supplementary frame assembly			

Fig. N. Abb. N.	Part. N. Bestell N. Piece N. Pieza N.	Qt. Anzahl	DESCRIZIONE	DESCRIPTION	BENENNUNG	DESCRIPTION	DESCRIPCION
33	Tav. 3 781301-0-20	1	targhetta classe testa	head class plate			
10	Tav. 4 724432-0-00	1	vite	screw			
28	Tav. 9 765200-6-80	2	ago sist. RIM 27 fin. 80	needle syst. RIM 27 size 80			
4	Tav. 13 204695-0-11	1	placca ago largh.costa 3,5 mm.	needle plate bight width 3,5 mm.			
6	204668-0-10	1	griffa sussidiaria	subsidiary feed dog			
7	204666-0-10	1	griffa principale	main feed dog			
17	Tav. 14 765200-6-80	10	ago sist. RIM 27 fin.80	needle syst. RIM 27 size 80			
			SOLO A RICHIESTA	ONLY ON REQUEST			
4	Tav. 13 204696-0-10	1	placca ago largh.costa 7 mm.	needle plate bight width 7 mm.			
	204809-0-00	1	placca ago largh.costa 5,5 mm.	needle plate bight width 5,5 mm.			
6	204808-2-11	1	griffa sussid.ricop. in Vulkollan	subsidiary feed dog			
	204999-0-00	1	griffa sussidiaria	subsidiary feed dog			
	205536-0-00	1	griffa sussid.(cromatura dura)	subsidiary feed dog			
7	204806-2-11	1	griffa princ.ricop. in Vulkollan	main feed dog			
	204998-0-00	1	griffa principale	main feed dog			
	205537-0-00	1	griffa principale (cromat.dura)	main feed dog			
19	203783-0-10	1	coltello superiore	upper knife			
	203759-0-10	1	coltello superiore	upper knife			
	207004-2-00	1	coltello sup. con placchetta	upper knife			
20	204693-0-11	1	coltello inferiore	lower knife			

Fig. N. Abb. N.	Part. N. Bestell N. Piece N. Pieza N.	Qt. Anzahl	DESCRIZIONE	DESCRIPTION	BENENNUNG	DESCRIPTION	DESCRIPCION
★	204706-3-11	1	piedino completo	presserfoot assembly			
1	204894-0-10	1	molla	spring			
2	204895-0-10	1	bussola filettata	bush			
3	204947-0-10	1	vite	screw			
4	204869-0-10	1	spina	pin			
5	204889-0-10	1	vite	screw			
6	741413-0-00	1	vite	screw			
7	204878-0-10	1	piastrina	plate			
	Tav. 3						
33	781302-0-20	1	targhetta classe testa	head class plate			
	Tav. 4						
10	724432-0-00	1	vite	screw			
	Tav. 9						
28	765200-6-80	2	ago sist. RIM 27 fin. 80	needle syst. RIM 27 size 80			
	Tav. 13						
4	204698-0-11	1	placca ago largh.costa 3,7 mm.	needle plate bight width 3,7 mm.			
5	204819-0-10	1	griffino	feed dog			
6	204669-0-10	1	griffa sussidiaria	subsidiary feed dog			
7	204667-0-10	1	griffa principale	main feed dog			
	Tav. 14						
17	765200-6-80	10	ago sist. RIM 27 fin. 80	needle syst. RIM 27 size 80			
			SOLO A RICHIESTA	ONLY ON REQUEST			
	Tav. 13						
4	204692-0-00	1	placca ago largh.costa 4 mm.	needle plate bight width 4 mm.			
	204696-0-10	1	placca ago largh.costa 7 mm.	needle plate bight width 7 mm.			
	206866-0-00	1	placca ago largh.costa 5 mm.	needle plate bight width 5 mm.			
19	203783-0-10	1	coltello superiore	upper knife			
	203759-0-10	1	coltello superiore	upper knife			
	207004-2-00	1	coltello super. con placchetta	upper knife			
20	204693-0-11	1	coltello inferiore	lower knife			

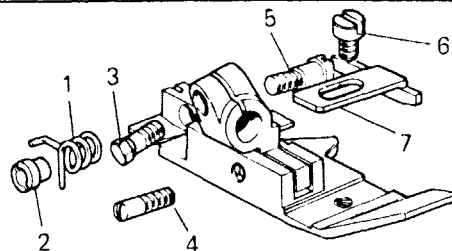

Fig. N. Abb. N.	Part. N. Bestell N. Pieza N.	Qt. Anzahl	DESCRIZIONE	DESCRIPTION	BENENNUNG	DESCRIPTION	DESCRIPCION
★	205103-3-10	1	piedino completo	presserfoot assembly			
1	204894-0-10	1	molla	spring			
2	204895-0-10	1	bussola filettata	bush			
3	204947-0-10	1	vite	screw			
4	204869-0-10	1	spina	pin			
5	204889-0-10	1	vite	screw			
6	741445-0-00	1	vite	screw			
7	205105-0-10	1	linguetta	tongue			
	205106-0-00	1	linguetta	tongue			
	<u>Tav. 3</u>						
33	781300-0-20	1	targhetta classe macchina	machine class plate			
	<u>Tav. 4</u>						
10	724432-0-00	1	vite	screw			
	<u>Tav. 11</u>						
17	205430-0-10	1	spingi asola	front needle guard			
	<u>Tav. 13</u>						
★	205101-4-10	1	gruppo spingi asola salva ago	front and rear needle guard group			
2	205100-0-10	1	spingi asola	front needle guard			
4	205102-0-10	1	placca ago largh. costa 3,5 mm.	needle plate bight width 3,5 mm.			
			SOLO A RICHIESTA	ONLY ON REQUEST			
	<u>Tav. 13</u>						
4	204696-0-10	1	placca ago largh. costa 7 mm.	needle plate bight width 7 mm.			
19	203783-0-10	1	coltello superiore	upper knife			
	203759-0-10	1	coltello superiore	upper knife			
	207004-2-00	1	coltello super. con placchetta	upper knife			
20	204693-0-11	1	coltello inferiore	lower knife			

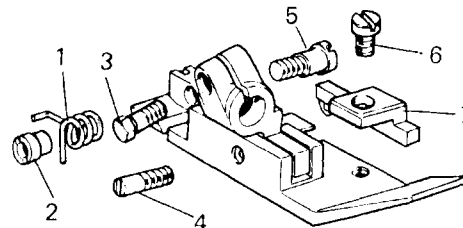

Fig. N. Abb. N.	Part. N. Bestell N. Pieza N.	Qt. Anzahl	DESCRIZIONE	DESCRIPTION	BENENNUNG	DESCRIPTION	DESCRIPCION
	<u>Tav. 3</u>						
33	781300-0-20	1	targhetta classe testa	head class plate			
	<u>Tav. 4</u>						
10	724432-0 00	1	vite	screw			
	<u>Tav. 13</u>						
4	204867-0-10	1	placca ago largh. costa 6 mm.	needle plate bight width 6 mm.			
6	204852-0-10	1	griffa sussidiaria	subsidiary feed dog			
7	204848-0-10	1	griffa principale	main feed dog			
			SOLO A RICHIESTA	ONLY ON REQUEST			
	<u>Tav. 13</u>						
6	204853-0-10	1	griffa sussidiaria	subsidiary feed dog			
7	204849-0-10	1	griffa principale	main feed dog			
19	203783-0-10	1	coltello superiore	upper knife			
	203759-0-10	1	coltello superiore	upper knife			
	207004-2-00	1	coltello super. con placchetta	upper knife with plate			
20	204693-0-11	1	coltello inferiore	lower knife			

Fig. N. Abb. N.	Part. N. Bestell N. Piece N. Pieza N.	Qt. Anzahl	DESCRIZIONE	DESCRIPTION	BENENNUNG	DESCRIPTION	DESCRIPCION
★	204951-3-11	1	pedino completo	presserfoot assembly			
1	204894-0-10	1	molla	spring			
2	204895-0-10	1	bussola filettata	bush			
3	204947-0-10	1	vite	screw			
4	204869-0-10	1	spina	pin			
5	204889-0-10	1	vite	screw			
6	741526-0-00	1	vite	screw			
7	204856-0-10	1	guida	guide			
8	991225-4-00	1	guida fettuccia completa	guide assembly			
9	991221-0-00	1	guida fettuccia	guide			
10	991222-0-00	1	asta di regolazione	rod			
11	703003-0-00	2	rondella elastica	spring washer			
12	991220-0-00	1	asta centrale	rod			
13	746003-0-00	3	dado	nut			
14	991223-0-00	1	supporto	support			
15	722420-2-00	3	vite	screw			
<u>Tav. 3</u>							
33	781300-0-20	1	targhetta classe macchina	machine class plate			
<u>Tav. 4</u>							
10	724432-0-00	1	vite	screw			
<u>Tav. 13</u>							
4	204948-0-10	1	placca ago largh.costa 4 mm.	needle plate bight width 4 mm.			
			SOLO A RICHIESTA	ONLY ON REQUEST			
<u>Tav. 13</u>							
4	204696-0-10	1	placca ago largh.costa 7 mm.	needle plate bight width 7 mm.			
19	203783-0-10	1	coltello superiore	upper knife			
	203759-0-10	1	coltello superiore	upper knife			
	207004-2-00	1	coltello super. con placchetta	upper knife			
20	204693-0-11	1	coltello inferiore	lower knife			

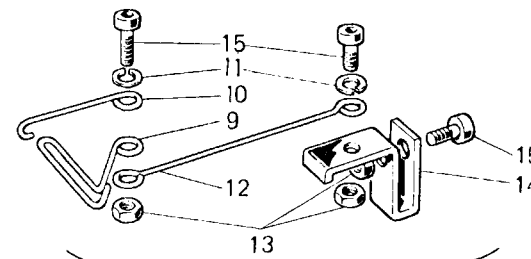
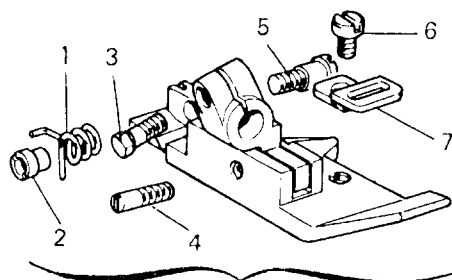
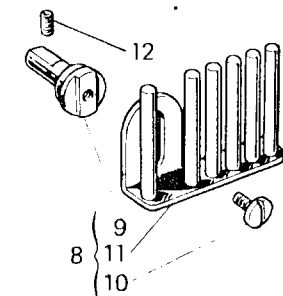
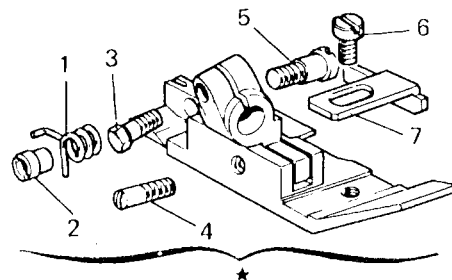

Fig. N. Abb. N.	Part. N. Bestell N. Piece N. Pieza N.	Qt. Anzahl	DESCRIZIONE	DESCRIPTION	BENENNUNG	DESCRIPTION	DESCRIPCION
★	204873-3-11	1	pedino completo	presserfoot assembly			
1	204894-0-10	1	molla	spring			
2	204895-0-10	1	bussola filettata	bush			
3	204497-0-10	1	vite	screw			
4	204869-0-10	1	spina	pin			
5	204889-0-10	1	vite	screw			
6	741413-0-00	1	vite	screw			
7	204879-0-11	1	piastrina	plate			
8	990496-4-10	1	gruppo frenaggio completo	brake device group			
9	990497-0-10	1	perno	pin			
10	201236-0-10	1	vite	screw			
11	990495-2-10	1	piastra frenaggio	plate			
12	729013-2-00	1	vite	screw			
<u>Tav. 3</u>							
33	781300-0-20	1	targhetta classe macchina	machine class plate			
★	206367-4-00	1	sportello anteriore completo	front cover			
16	206955-2-00	1	sportello scorrevole	sliding cover			
<u>Tav. 4</u>							
10	724432-0-00	1	vite	screw			
<u>Tav. 13</u>							
4	206172-2-00	1	placca ago con guida largh. costa 4,5 mm.	needle plate with guide bight width 4,5 mm.			
7	206176-0-00	1	griffa principale	main feed dog			
			SOLO A RICHIESTA	ONLY ON REQUEST			
<u>Tav. 13</u>							
4	204696-0-10	1	placca ago largh. costa 7 mm	needle plate bight width 7 mm.			
19	203783-0-10	1	coltello superiore	upper knife			
	203759-0-10	1	coltello superiore	upper knife			
	207004-2-00	1	coltello super. con placchetta	upper knife			
20	204693-0-11	1	coltello inferiore	lower knife			
			PEZZI ANNULLATI	CANCELLED PARTS			
<u>Tav. 2</u>							
16	202398-0-10	1	tappo	plug			



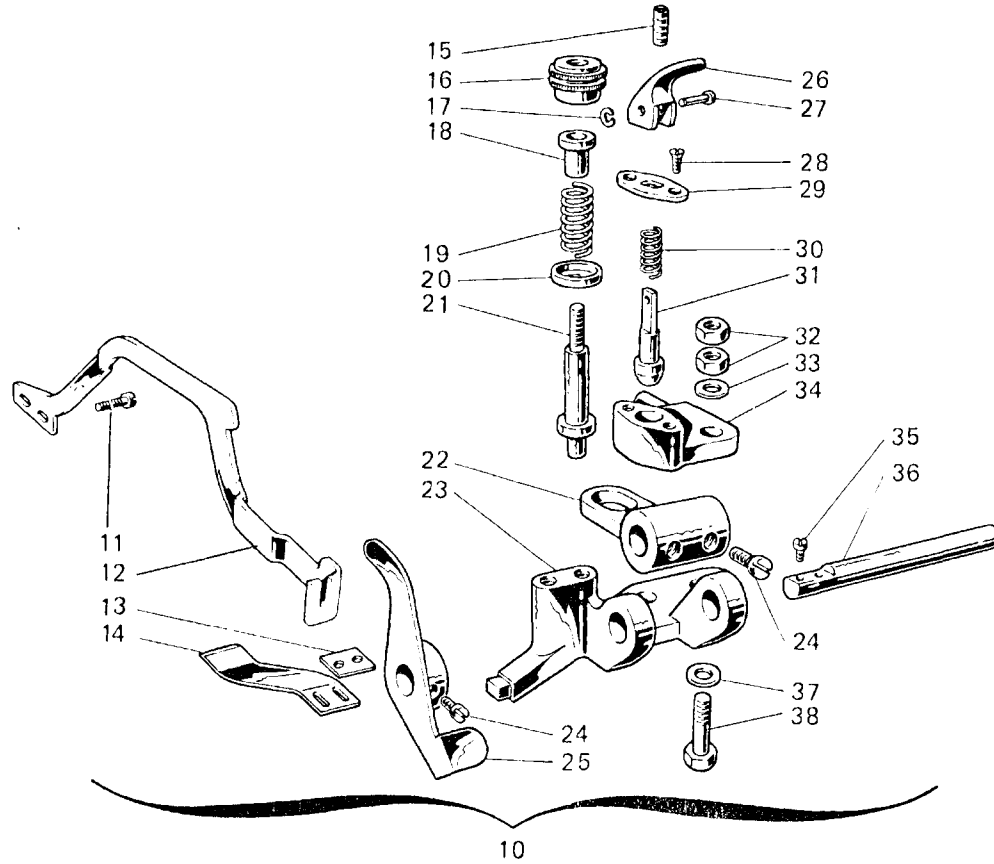
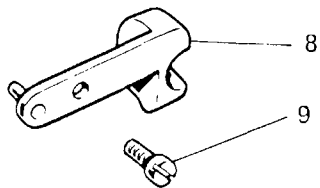
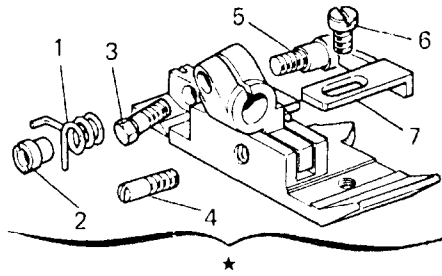

Fig. N. Abb. N.	Part. N. Bestell N. Pieza N.	Qt. Anzahl	DESCRIZIONE	DESCRIPTION	BENENNUNG	DESCRIPTION	DESCRIPCION
★	204875-3-11	1	pedino completo	presserfoot assembly			
1	204894-0-10	1	molla	spring			
2	204895-0-10	1	bussola filettata	bush			
3	204947-0-10	1	vite	screw			
4	204869-0-10	1	spina	pin			
5	204889-0-10	1	vite	screw			
6	741431-0-00	1	vite	screw			
7	204880-0-10	1	piastrina	plate			
8	203193-2-10	1	squadretta con spina	bracket			
9	721443-2-00	1	vite	screw			
10	204915-4-12	1	pieghettatore completo	folding device assembly			
11	300483-0-10	2	vite	screw			
12	206923-0-00	1	leva alza pieghettatore	lever			
13	204964-0-00	1	piastrina	plate			
14	204916-0-10	1	lamina	plate			
15	729013-2-00	1	vite	screw			
16	200699-0-10	1	pomolo	knob			
17	700205-0-00	1	anello elastico	spring ring			
18	200074-0-10	1	bussola	bush			
19	204937-0-10	1	molla	spring			
20	200821-0-10	1	scodellino	cap			
21	200698-0-10	1	perno	pin			
22	204926-0-10	1	leva premi-lamina	lever			
23	204914-0-10	1	corpo del pieghettatore	folding device body			
24	721434-2-00	4	vite	screw			
25	204924-2-10	1	leva	lever			
26	206909-0-00	1	leva per puntale	lever			
27	202100-0-10	1	spina	pin			
28	744533-0-00	2	vite	screw			
29	204935-0-10	1	piastrina	plate			
30	204938-2-00	1	molla premistoffa	spring			
31	204936-0-10	1	puntale	pin			
32	746021-2-00	2	dado	nut			
33	704216-2-00	1	rondella	washer			
34	204927-0-10	1	sostegno	support			
35	741675-2-00	2	vite	screw			
36	204918-0-10	1	perno porta lamina	pin			
37	704424-2-00	1	rondella	washer			
38	204934-0-10	1	vite	screw			
	<u>Tav. 3</u>						
33	781300-0-20	1	targhetta classe macchina	machine class plate			
	<u>Tav. 4</u>						
10	724432-0-10	1	vite	screw			
	<u>Tav. 9</u>						
28	765200-6-10	2	ago sist. RIM 27 fin. 100	needle syst. RIM 27 size 100			

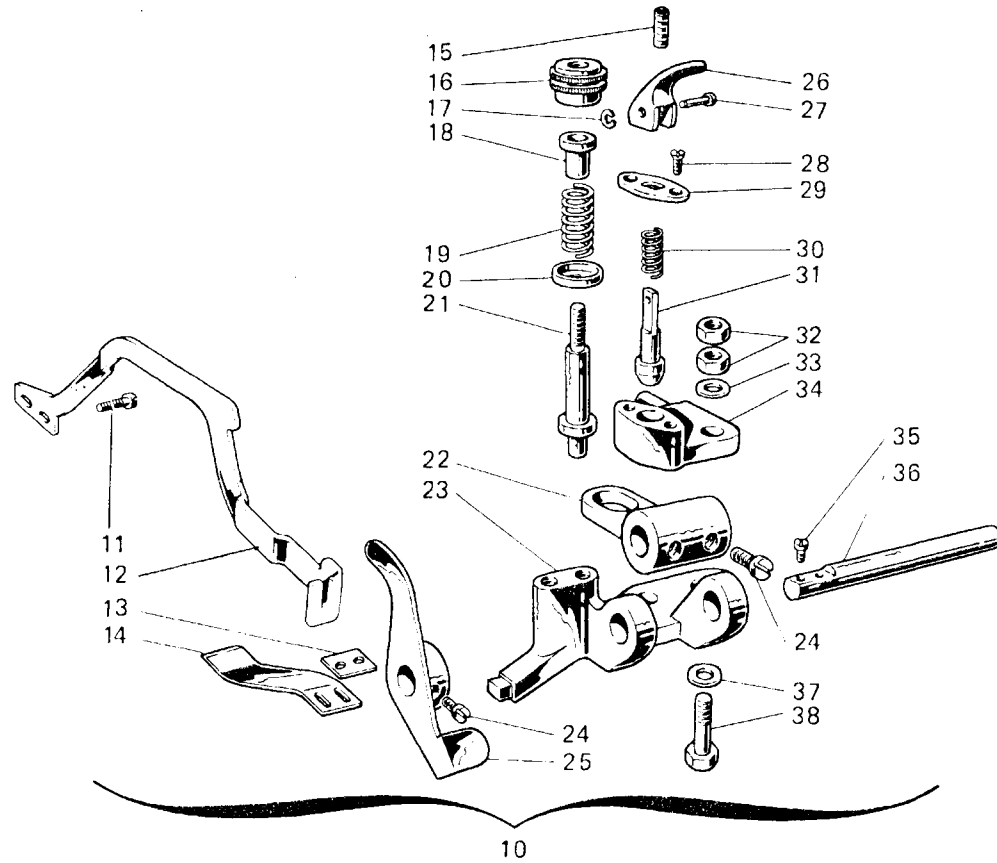
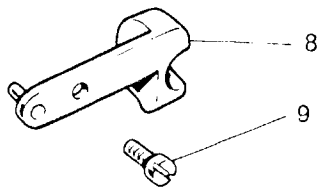
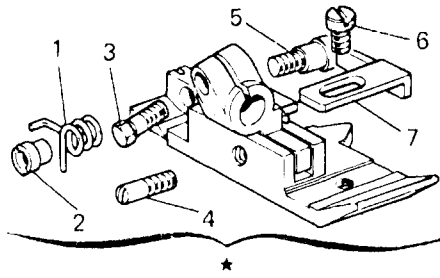

Fig. N. Abb. N.	Part. N. Bestell N. Piece N. Pieza N.	Qt. Anzahl	DESCRIZIONE	DESCRIPTION	BENENNUNG	DESCRIPTION	DESCRIPCION
<u>Tav. 13</u>							
4	204867-0-10	1	placca ago largh.costa 6 mm.	needle plate bight width 6 mm.			
6	204852-0-10	1	griffa sussidiaria	subsidiary feed dog			
7	204848-0-10	1	griffa principale	main feed dog			
<u>Tav. 14</u>							
17	765200-6-10	10	aghi sist. RIM 27 fin. 100	needle syst. RIM 27 size 100			
<u>Tav. 16</u>							
★	920245-4-00	1	ginocchiello	knee			
<u>SOLO A RICHIESTA</u> <u>ONLY ON REQUEST</u>							
<u>Tav. 13</u>							
4	204949-0-10	1	placca ago largh.costa 4,5 mm.	needle plate bight width 4,5 mm.			
7	204849-0-10	1	griffa principale	main feed dog			
	204853-0-10	1	griffa principale	main feed dog			
	205615-0-00	1	griffa unica	feed dog			
19	203783-0-10	1	coltello superiore	upper knife			
	203759-0-10	1	coltello superiore	upper knife			
	207004-2-00	1	coltello super. con placchetta	upper knife with plate			
20	204693-0-11	1	coltello inferiore	lower knife			
<u>PEZZI ANNULLATI</u> <u>CANCELLED PARTS</u>							
<u>Tav. 2</u>							
16	202398-0-10	1	tappo	plug			
<u>Tav. 10</u>							
16	204891-0-11	1	molla premi piedino	spring			
17	203187-0-10	1	vite	screw			

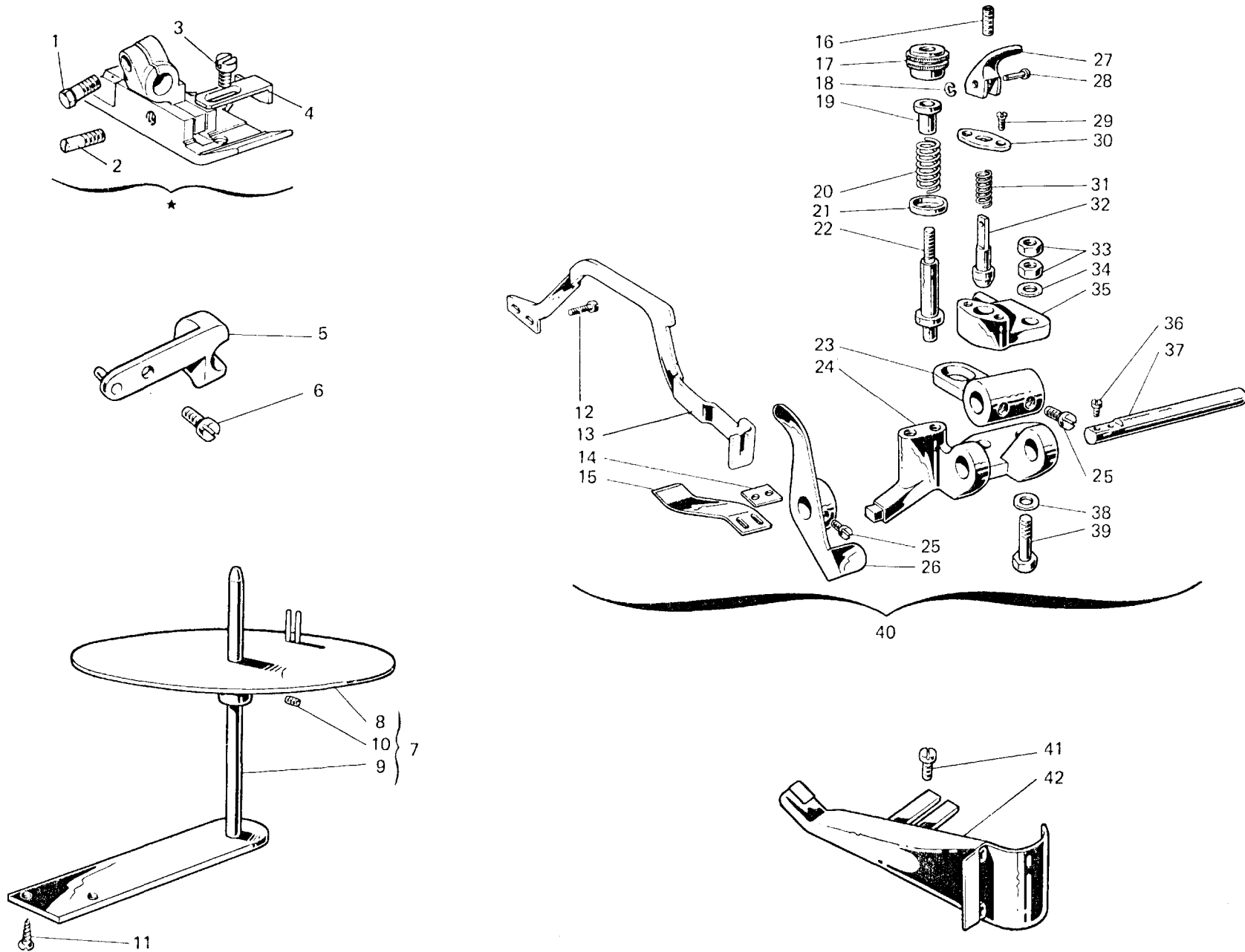
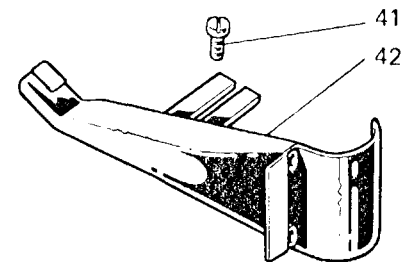
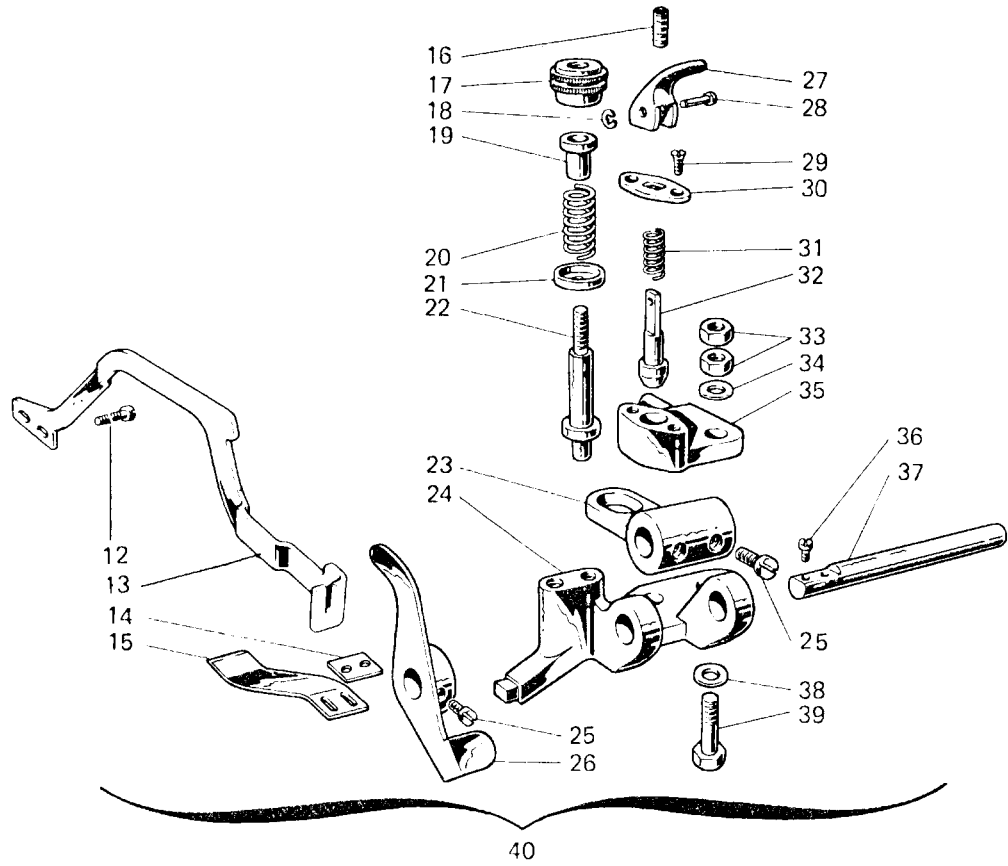
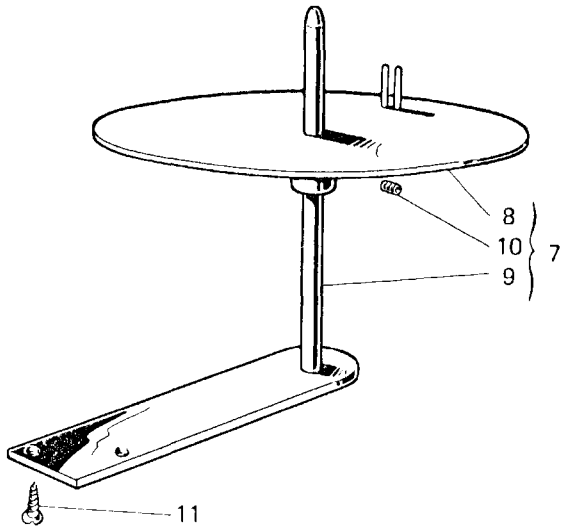
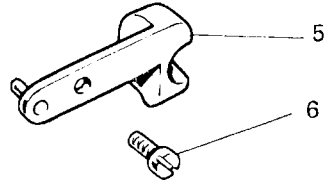
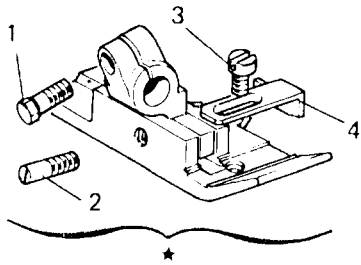

Fig. N. Abb. N.	Part. N. Bestell N. Pieze N. Pieza N.	Qt. Anzahl	DESCRIZIONE	DESCRIPTION	BENENNUNG	DESCRIPTION	DESCRIPCION
	<u>Tav. 3</u>						
33	781300-0-20	1	targhetta classe testa	head class plate			
	<u>Tav. 4</u>						
10	724432-0-00	1	vite	screw			
	<u>Tav. 9</u>						
28	765200-6-10	2	ago sist. RIM 27 fin. 100	needle syst. RIM 27 size 100			
	<u>Tav. 13</u>						
4	204867-0-10	1	placca ago largh.costa 6 mm.	needle plate bight width 6 mm.			
6	204852-0-10	1	griffa sussidiaria	subsidiary feed dog			
7	204848-0-10	1	griffa principale	main feed dog			
	<u>Tav. 14</u>						
17	765200-6-10	10	ago sist. RIM 27 fin. 100	needle syst. RIM 27 size 100			
	<u>Tav. 16</u>						
★	920245-4-00	1	ginocchietto	knee-press			
			SOLO A RICHIESTA	ONLY ON REQUEST			
	<u>Tav. 13</u>						
4	204949-0-10	1	placca ago largh.costa 4,5 mm.	needle plate bight width 4,5 mm.			
19	203783-0-10	1	coltello superiore	upper knife			
	203759-0-10	1	coltello superiore	upper knife			
	207004-2-00	1	coltello super. con placchetta	upper knife			
20	204693-0-11	1	coltello inferiore	lower knife			
	<u>Tav. 25</u>						
41	204958-2-10	1	guida cordoncino mm. 3 e fettuccia mm. 20	guide			
			PEZZI ANNULLATI	CANCELLED PARTS			
	<u>Tav. 2</u>						
16	202398-0-10	1	tappo	plug			

Fig. N. Abb. N.	Part. N. Bestell N. Pieze N. Pieza N.	Qt. Anzahl	DESCRIZIONE	DESCRIPTION	BENENNUNG	DESCRIPTION	DESCRIPCION
★	204876-3-11	1	pedino completo	presserfoot assembly			
1	204947-0-10	1	vite	screw			
2	204869-0-10	1	spina	pin			
3	741431-0-00	1	vite	screw			
4	204881-0-10	1	piastrina	plate			
5	203193-2-10	1	squadretta con spina	bracket with pin			
6	721443-2-10	1	vite	screw			
7	990397-4-10	1	gruppo porta rotolo	roller carrier assembly			
8	990396-3-10	1	piatto completo	assembly disc			
9	990558-2-10	1	telailetto con asta	frame whit rod			
10	727245-2-00	2	vite	screw			
11	731295-0-00	2	vite	screw			
12	300483-0-10	2	vite	screw			
13	206923-0-00	1	leva alza pieghettatore	lever			
14	204964-0-00	1	piastrina	plate			
15	204916-0-10	1	lamina	sheet			
16	729013-2-00	1	vite	screw			
17	200699-0-10	1	pomolo	knob			
18	700205-0-00	1	anello elastico	spring ring			
19	200074-0-10	1	bussola	bush			
20	204937-0-10	1	molla	spring			
21	200821-0-10	1	scodellino	cap			
22	200698-0-10	1	perno	pin			
23	204926-0-10	1	leva premi lamina	lever			
24	204914-0-10	1	corpo del pieghettatore	folding device body			
25	721434-2-00	4	vite	screw			
26	204924-2-10	1	leva	lever			
27	206909-0-00	1	leva per puntale	lever			
28	202100-0-10	1	spina	pin			
29	744533-0-00	2	vite	screw			
30	204935-0-10	1	piastrina	plate			
31	204938-2-00	1	molla premi puntale	spring			
32	204936-0-10	1	puntale	pin			
33	746021-2-00	2	dado	nut			
34	704216-2-00	1	rondella	washer			
35	204927-0-10	1	sostegno	support			
36	741675-2-00	2	vite	screw			
37	204918-0-10	1	perno porta lamina	pin			
38	704424-2-00	1	rondella	washer			
39	204934-0-10	1	vite	screw			
40	204915-4-12	1	pieghettatore completo	folding device assembly			
41	721444-2-00	2	vite	screw			
42	204930-2-10	1	guida cordoncino	guide			



Rimoldi

VARIANTE PER

VARIATION FOR

329-00-2CD-03

329-00-2CD-04

329-00-2CD-09

329-00-2CD-11

329-22-2CD-02

329-23-2CD-02

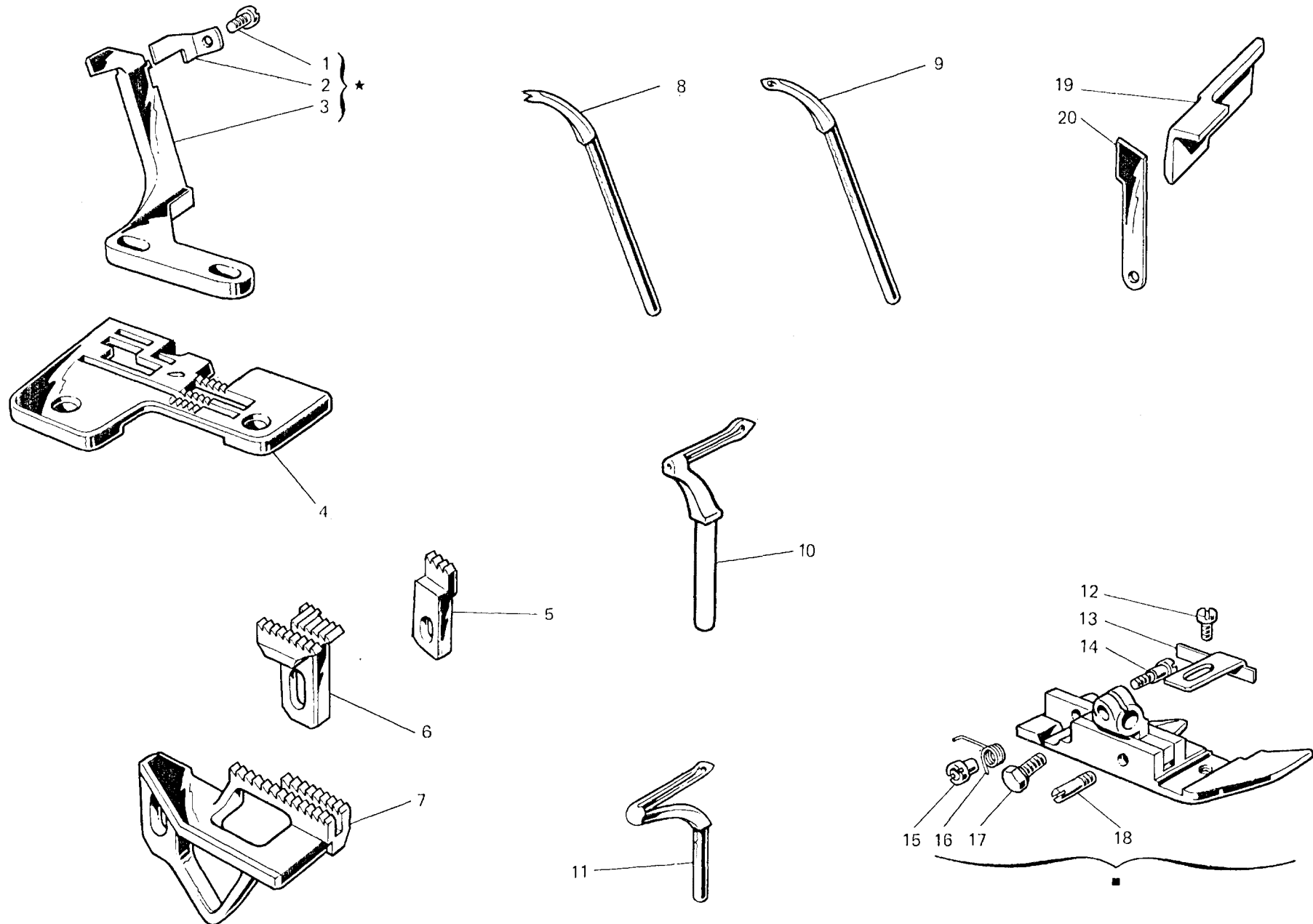

Fig. N. Abb. N.	Part. N. Bestell N. Piece N. Pieza N.	Qt. Anzahl	DESCRIZIONE	DESCRIPTION	BENENNUNG	DESCRIPTION	DESCRIPCION
★	204862-4-10	1	gruppo salva ago e spingi asola	rear and front needle guard assembly			
1	741431-0-00	1	vite	screw			
2	204861-0-10	1	spingi asola	front needle guard			
3	204863-0-10	1	salva ago	rear needle guard			
4	204821-0-10	1	placca ago largh.costa 3 mm	needle plate bight width 3 mm.			
5	204819-0-10	1	griffino	feed-dog			
6	204816-0-10	1	griffa sussidiaria	subsidiary feed dog			
7	204813-0-10	1	griffa principale	main feed dog			
8	202092-0-10	1	crochet sup.cieco cucit.a 4 fili	upper looper (blind)			
9	204033-0-10	1	crochet sup.cieco cucit.a 5 fili	upper looper (blind)			
10	204675-0-10	1	crochet punto sicurezza	looper			
11	202413-0-11	1	crochet inferiore	lower looper			
12	741413-0-00	1	vite	screw			
13	204878-0-10	1	piastrina	plate			
14	204889-0-10	1	vite	screw			
15	204895-0-10	1	bussola filettata	bush			
16	204894-0-10	1	molla	spring			
17	204947-0-10	1	vite	screw			
18	204869-0-10	1	spina	pin			
19	207003-2-00	1	coltello superiore	upper knife			
20	207020-2-01	1	coltello inferiore	lower knife			
■	204826-3-10	1	pedino completo	presserfoot assembly			
	<u>Tav. 26</u>		SOLO A RICHIESTA	ONLY ON REQUEST			
4	204837-0-00	1	placca ago largh.costa 2,5~mm.	needle plate bight width 2,5~mm.			
	204838-0-00	1	placca ago largh.costa 5 mm.	needle plate bight width 5 mm.			
6	205538-0-00	1	griffa sussidiaria	subsidiary feed-dog			
7	205539-0-00	1	griffa principale	main feed-dog			
19	203783-0-10	1	coltello superiore	upper knife			
	203759-0-10	1	coltello superiore	upper knife			
	207004-2-00	1	coltello superiore con placchetta	upper knife			
20	204693-0-11	1	coltello inferiore	lower knife			
	<u>Tav. 3</u>						
33	781303-0-20	1	targhetta classe testa	head class plate			
	<u>Tav. 9</u>						
★	206430-4-00	1	cinematismo comando ago	needle control assembly			
27	206830-4-00	1	barra ago con morsetto e fig.24-25	needle bar with clamp fig.24-25			
28	765200-6-80	1	ago sist.RIM27 fin.80	needle RIM27 fin 80			
	<u>Tav. 14</u>						
17	765200-6-80	10	ago sistema RIM 27 fin.80	needle RIM 27 fin. 80			

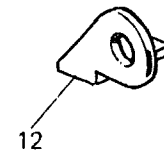
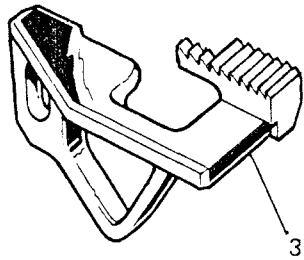
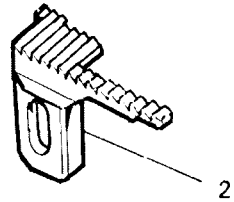
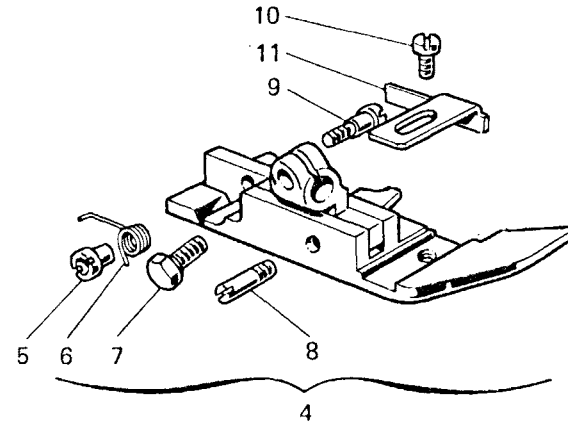
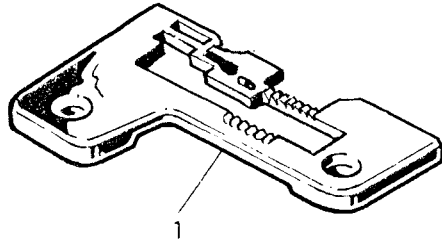

Fig. N. Abb. N.	Part. N. Bestell N. Pieca N. Pieza N.	Ct. Anzahl	DESCRIZIONE	DESCRIPTION	BENENNUNG	DESCRIPTION	DESCRIPCION
1	204822-0-10	1	placca ago largh.costa 3 mm.	needle plate bight width 3 mm.			
2	204817-0-10	1	griffa sussidiaria	subsidiary feed dog			
3	204814-0-10	1	griffa principale	main feed dog			
4	204827-3-10	1	pedino completo	presserfoot assembly			
5	204895-0-10	1	bussola filettata	bush			
6	204894-0-10	1	molla	spring			
7	204947-0-10	1	vite	screw			
8	204869-0-10	1	spina	pin			
9	204889-0-10	1	vite	screw			
10	741413-0-00	1	vite	screw			
11	204878-0-10	1	piastrina	plate			
12	204836-0-10	1	squadretta di fermo	bracket			
			<u>Tav. 3</u>				
33	781304-0-20	1	targhetta classe testa	head class plate			
			<u>Tav. 4</u>				
10	724432-0-00	1	vite	screw			
			SOLO A RICHIESTA ONLY ON REQUEST				
			<u>Tav. 27</u>				
1	204823-0-10	1	placca ago largh.costa 3 mm.	needle plate bight width 3 mm.			
			<u>Tav. 26</u>				
19	203783-0-10	1	coltello superiore	upper knife			
	203759-0-10	1	coltello superiore	upper knife			
	207004-2-00	1	coltello superiore con placchetta	upper knife			
20	204693-0-11	1	coltello inferiore	lower knife			
			PEZZI ANNULLATI CANCELLED PARTS				
			<u>Tav. 10</u>				
16	204981-0-10	1	molla premi pedino	spring			

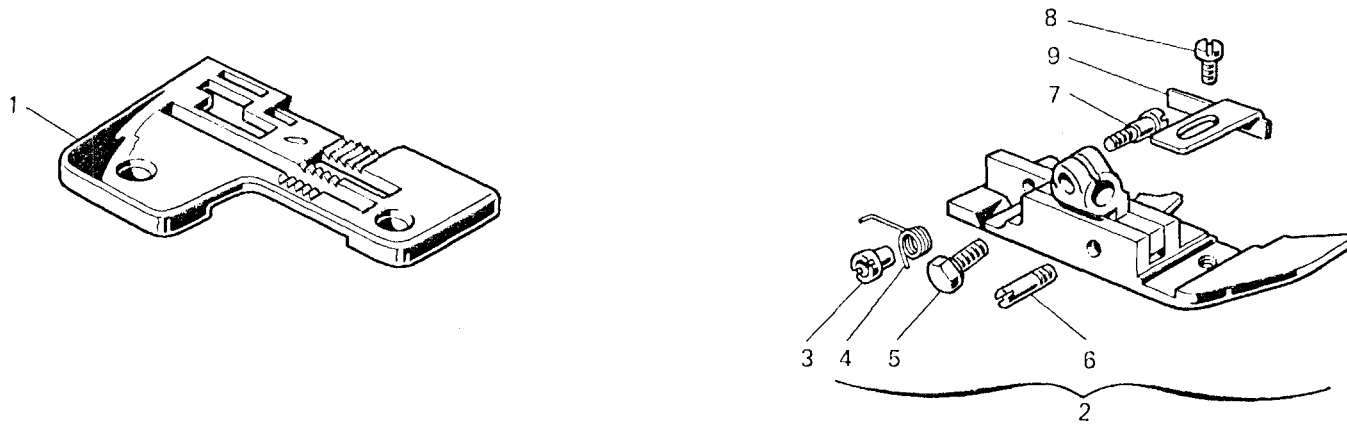

Fig. N. Abb. N.	Part. N. Bestell N. Piece N. Pieza N.	Qt. Anzahl	DESCRIZIONE	DESCRIPTION	BENENNUNG	DESCRIPTION	DESCRIPCION
1	205082-0-10	1	placca ago largh.costa 2,5 mm	needle plate bight width 2,5 mm.			
2	205084-0-10	1	piedino completo	presserfoot assembly			
3	204895-0-10	1	bussola filettata	bush			
4	204894-0-10	1	molla	spring			
5	204947-0-10	1	vite	screw			
6	204869-0-10	1	spina	pin			
7	204889-0-10	1	vite	screw			
8	741433-0-00	1	vite	screw			
9	205088-0-10	1	piastrina	plate			
	<u>Tav. 3</u>						
33	781300-0-20	1	targhetta classe testa	head class plate			
	<u>Tav. 4</u>						
10	724432-0-00	1	vite	screw			
	<u>Tav. 26</u>						
★	205081-4-10	1	gruppo salva ago e spingi asola	rear and front needle guard assembly			
3	205080-0-10	1	spingi asola	front needle guard			
			SOLO A RICHIESTA	ONLY ON REQUEST			
	<u>Tav. 26</u>						
19	203783-0-10	1	coltello superiore	upper knife			
	203759-0-10	1	coltello superiore	upper knife			
	207004-2-00	1	coltello superiore con placchetta	upper knife			
20	204693-0-11	1	coltello inferiore	lower knife			
	<u>Tav. 28</u>						
1	204823-0-10	1	placca ago largh.costa 3 mm.	needle plate bight width 3 mm.			

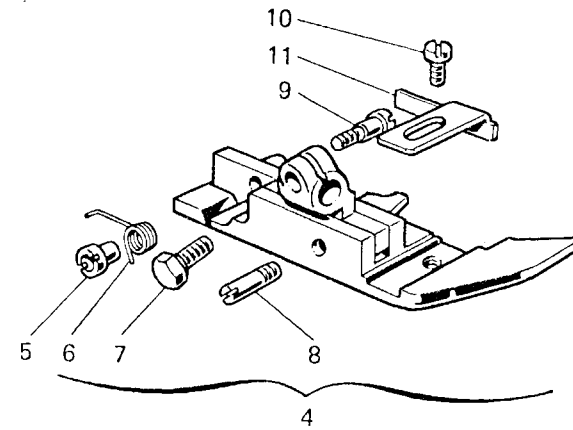
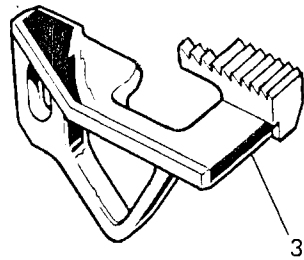
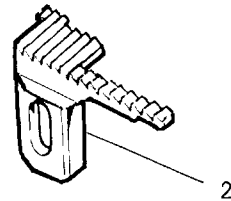
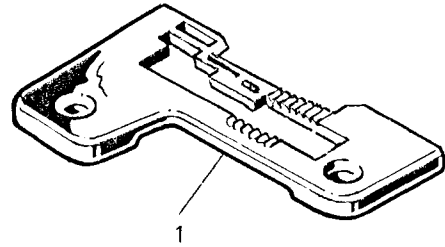

Fig. N. Abb. N.	Part. N. Bestell N. Piece N. Pieza N.	Qt. Anzahl	DESCRIZIONE	DESCRIPTION	BENENNUNG	DESCRIPTION	DESCRIPCION
1	205083-0-10	1	placca ago largh.costa 3 mm.	needle plate bight width 3 mm			
2	204817-0-10	1	griffa sussidiaria	subsidiary feed dog			
3	204814-0-10	1	griffa principale	main feed dog			
4	205085-3-10	1	piedino completo	presserfoot assembly			
5	204895-0-10	1	bussola filettata	bush			
6	204894-0-10	1	molla	spring			
7	204947-0-10	1	vite	screw			
8	204869-0-10	1	spina	pin			
9	204889-0-10	1	vite	screw			
10	741433-0-00	1	vite	screw			
11	205088-0-10	1	piastrina	plate			
	<u>Tav. 3</u>						
33	781300-0-20	1	targhetta classe testa	head class plate			
	<u>Tav. 4</u>						
10	724432-0-00	1	vite	screw			
	<u>Tav. 26</u>						
★	205081-4-10	1	gruppo salva ago e spingi asola	rear and front needle guard assembly			
3	205080-0-10	1	spingi asola	front needle guard			
			SOLO A RICHIESTA	ONLY ON REQUEST			
	<u>Tav. 26</u>						
19	203783-0-10	1	coltello superiore	upper knife			
	203759-0-10	1	coltello superiore	upper knife			
	207004-2-00	1	coltello superiore con placchetta	upper knife			
20	204693-0-11	1	coltello inferiore	lower knife			
	<u>Tav. 29</u>						
1	204823-0-10	1	placca ago largh.costa 3 mm.	needle plate bight width 3mm.			

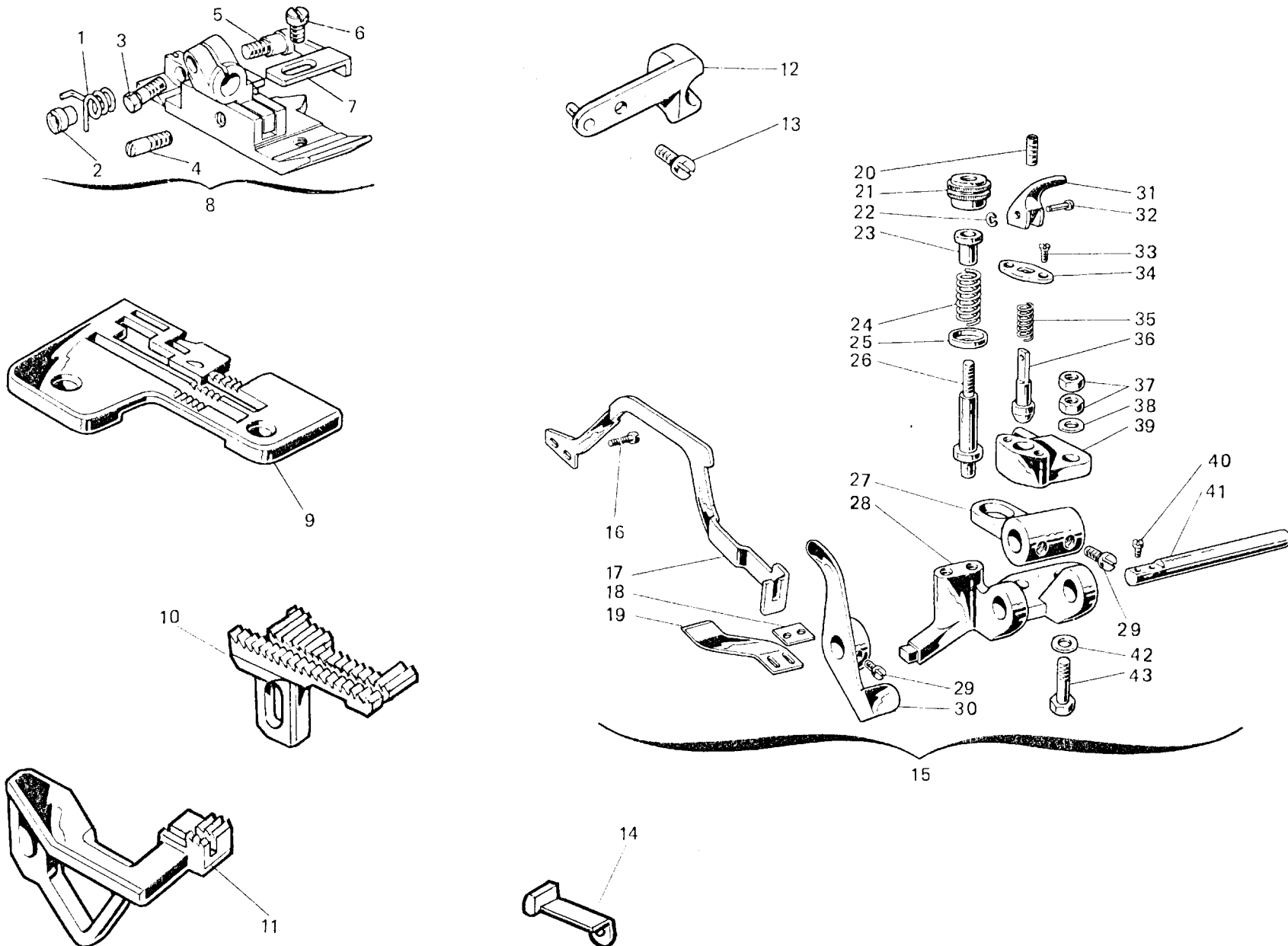

Fig. N. Abb. N.	Part. N. Bestell N. Piece N. Pieza N.	Qt. Anzahl	DESCRIZIONE	DESCRIPTION	BENENNUNG	DESCRIPTION	DESCRIPCION
1	204894-0-10	1	molla	spring			
2	204895-0-10	1	bussola filettata	bush			
3	204947-0-10	1	vite	screw			
4	204869-0-10	1	spina	pin			
5	204889-0-10	1	vite	screw			
6	741431-0-10	1	vite	screw			
7	204880-0-10	1	piastrina	plate			
8	204828-3-10	1	piedino completo	presserfoot assembly			
9	204824-0-10	1	placca ago largh. costa 3 mm.	needle plate bight width 3 mm.			
10	204818-0-10	1	griffa sussidiaria	subsidiary feed dog			
11	204815-0-10	1	griffa principale	main feed dog			
12	203193-2-10	1	squadretta con spina	bracket with pin			
13	721443-0-10	1	vite	screw			
14	204820-0-10	1	spingi asola	front needle guard			
15	204915-4-12	1	pieghettatore completo	folding device			
16	300483-0-10	2	vite	screw			
17	206923-0-00	1	leva alza pieghettatore	lever			
18	204964-0-00	1	piastrina	plate			
19	204916-0-10	1	lamina	sheet			
20	729013-2-00	1	vite	screw			
21	200699-0-10	1	pomolo	knob			
22	700205-0-00	1	anello elastico	spring ring			
23	200074-0-10	1	bussola	bush			
24	204937-0-10	1	molla	spring			
25	200821-0-10	1	scodellino	cup			
26	200698-0-10	1	perno	pin			
27	204926-0-10	1	leva premi lamina	lever			
28	204914-0-10	1	corpo del pieghettatore	folding body			
29	721434-2-00	4	vite	screw			
30	204924-2-10	1	leva	lever			
31	206909-0-00	1	leva per puntale	lever			
32	202100-0-10	1	spina	pin			
33	744533-0-00	2	vite	screw			
34	204935-0-10	1	piastrina	plate			
35	204938-2-00	1	molla premi puntale	spring			
36	202936-0-10	1	puntale	cup			
37	746021-2-00	2	dado	nut			
38	704216-2-00	1	rondella	washer			
39	204927-0-10	1	sostegno	support			
40	741675-2-00	2	vite	screw			
41	204918-0-10	1	perno porta lamina	pin			
42	704424-2-00	1	rondella	washer			
43	204934-0-10	1	vite	screw			
33	Tav. 3 781300-0-20	1	targhetta classe testa	head class plate			

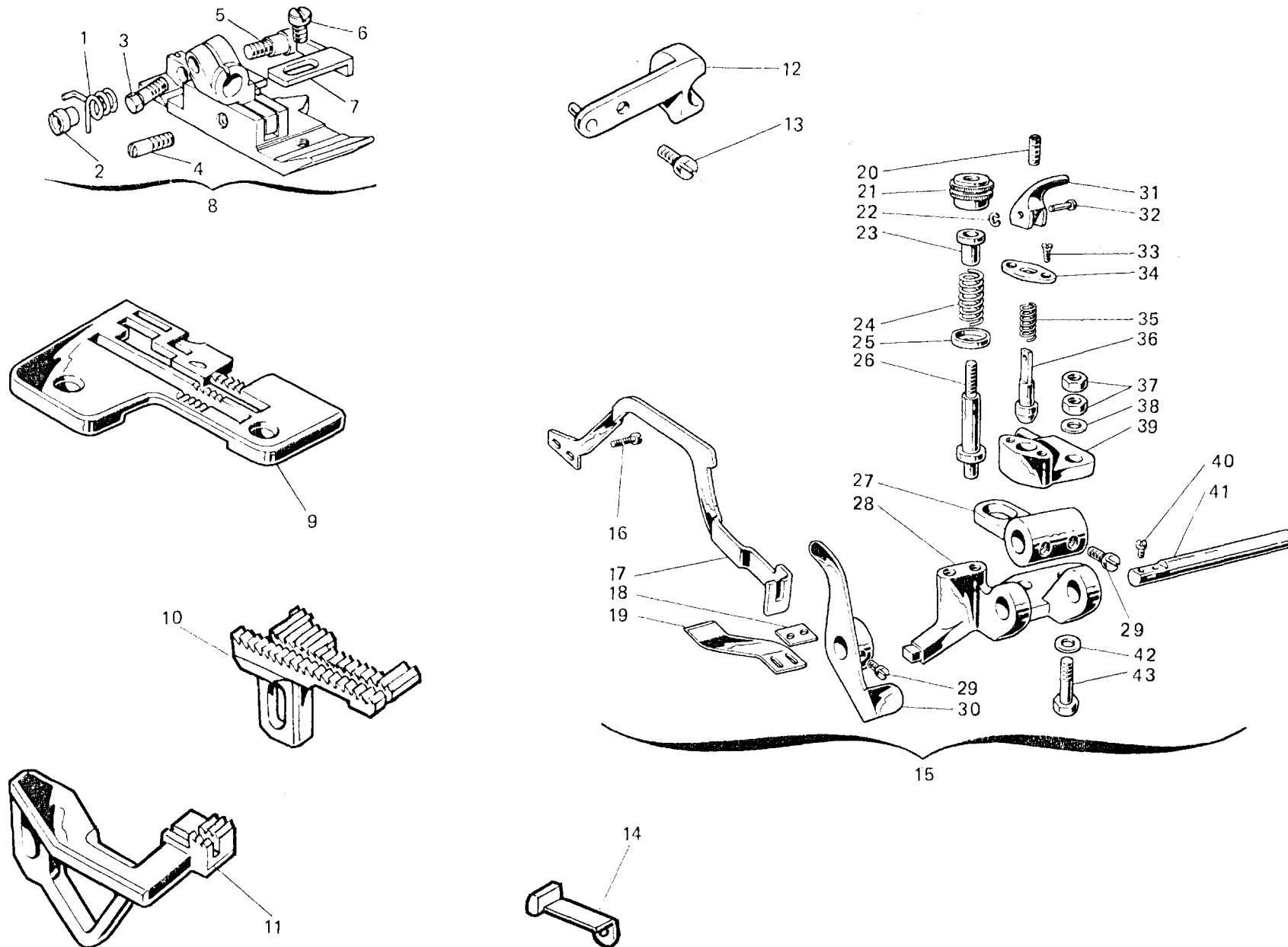

Fig. N. Abb. N.	Part. N. Bestell N. Piece N. Pieza N.	Qt. Anzahl	DESCRIZIONE	DESCRIPTION	BENENNUNG	DESCRIPTION	DESCRIPCION
10	<u>Tav. 4</u> 724432-0-00	1	vite	screw			
28	<u>Tav. 9</u> 765200-6-80	2	ago sistema RIM27 fin.80	needle RIM27 fin.80			
17	<u>Tav. 14</u> 765200-6-80	10	ago sistema RIM27 fin.80	needle RIM27 fin.80			
			SOLO A RICHIESTA	ONLY ON REQUEST			
19	<u>Tav. 26</u> 203783-0-10	1	coltello superiore	upper knife			
	203759-0-10	1	coltello superiore	upper knife			
	207004-2-00	1	coltello superiore con placchetta	upper knife			
20	204693-0-11	1	coltello inferiore	lower knife			
			PEZZI ANNULLATI	CANCELLED PARTS			
16	<u>Tav. 2</u> 202398-0-10	1	tappo	plug			
16	<u>Tav. 10</u> 204891-0-10	1	molla premi piedino	spring			
17	203187-0-10	1	vite	screw			

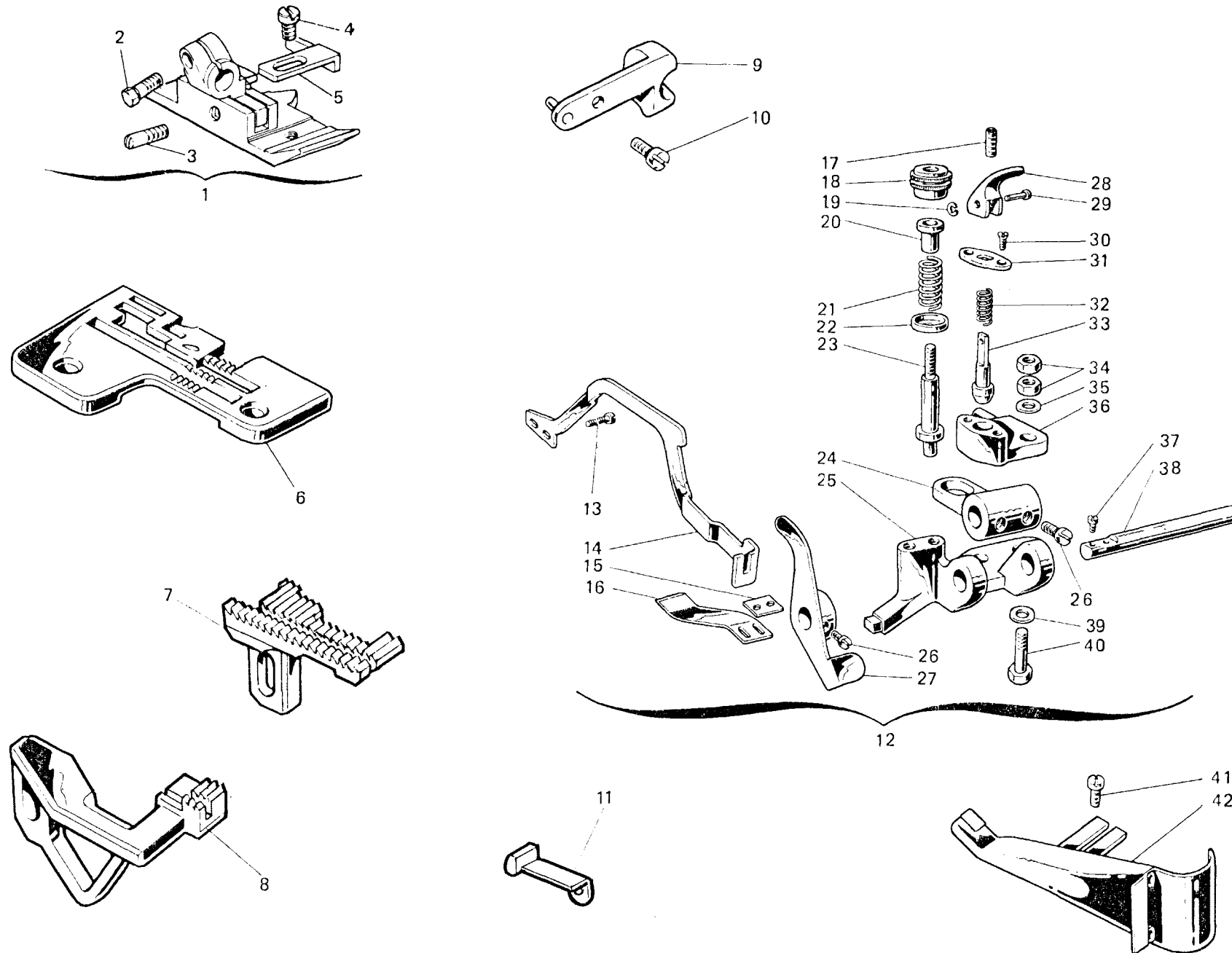

Fig. N. Abb. N.	Part. N. Bestell N. Piece N. Pieza N.	Qt. Anzahl	DESCRIZIONE	DESCRIPTION	BENENNUNG	DESCRIPTION	DESCRIPCION
1	204829-3-10	1	piedino completo	presserfoot assembly			
2	204947-0-10	1	vite	screw			
3	204869-0-10	1	spina	pin			
4	741431-0-10	1	vite	screw			
5	204881-0-10	1	piastrina	plate			
6	204824-0-10	1	placca ago largh.costa 3 mm	needle plate bight width 3 mm.			
7	204818-0-10	1	griffa sussidiaria	subsidiary feed dog			
8	204815-0-10	1	griffa principale	main feed dog			
9	203193-2-10	1	squadretta con spina	bracket with pin			
10	721443-0-10	1	vite	screw			
11	204820-0-10	1	spingi asola	front needle guard			
12	204915-4-12	1	pieghettatore completo	folding device			o
13	300483-0-10	2	vite	screw			
14	206923-0-00	1	leva alza pieghettatore	lever			
15	204964-0-00	1	piastrina	plate			
16	204916-0-10	1	lamina	sheet			
17	729013-2-00	1	vite	screw			
18	200699-0-10	1	pomolo	knob			
19	700205-0-00	1	anello elastico	spring ring			
20	200074-0-10	1	bussola	bush			
21	204937-0-10	1	molla	spring			
22	200821-0-10	1	scodellino	cup			
23	200698-0-10	1	perno	pin			
24	204926-0-10	1	leva premi lamina	lever			
25	204914-0-10	1	corpo del pieghettatore	folding body			
26	721434-2-00	4	vite	screw			
27	204924-2-10	1	leva	lever			
28	206909-0-00	1	leva per puntale	lever			
29	202100-0-10	1	spina	pin			
30	744533-0-00	2	vite	screw			
31	204935-0-10	1	piastrina	plate			
32	204938-2-00	1	molla premi puntale	spring			
33	202936-0-10	1	puntale	cup			
34	746021-2-00	2	dado	nut			
35	704216-2-00	1	rondella	washer			
36	204927-0-10	1	sostegno	support			
37	741675-2-00	2	vite	screw			
38	204918-0-10	1	perno porta lamina	pin			
39	704424-2-00	1	rondella	washer			
40	204934-0-10	1	vite	screw			
41	721444-2-00	2	vite	screw			
42	204930-2-10	1	guida	guide			
33	Tav. 3 781300-0-20	1	targhetta classe testa	head class plate			

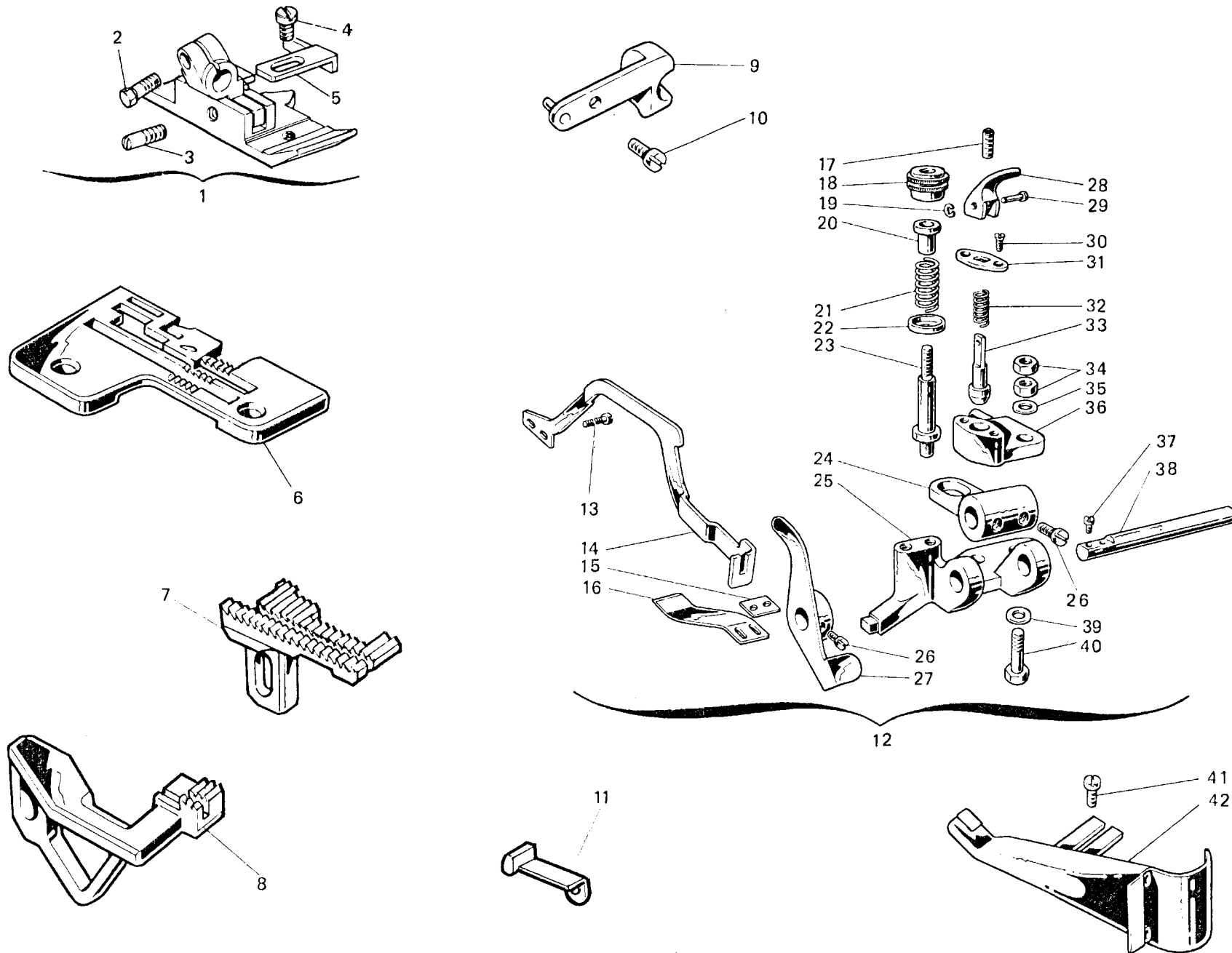

Fig. N. Abb. N.	Part. N. Bestell N. Piece N. Pieza N.	Qt. Anzahl	DESCRIZIONE	DESCRIPTION	BENENNUNG	DESCRIPTION	DESCRIPCION
10	Tav. 4 724432-0-00	1	vite	screw			
28	Tav. 9 765200-6-80	2	ago sistema RIM27 fin.80	needle RIM27 fin.80			
17	Tav. 14 765200-6-80	10	ago sistema RIM27 fin.80	needle RIM27 fin.80			
			SOLO A RICHIESTA	ONLY ON REQUEST			
19	Tav. 26 203783-0-10	1	coltello superiore	upper knife			
	203759-0-10	1	coltello superiore	upper knife			
20	207004-2-00	1	coltello superiore con placchetta	upper knife			
	204693-0-11	1	coltello inferiore	lower knife			
42	Tav. 31 204958-2-10	1	guida	guide			
			PEZZI ANNULLATI	CANCELLED PARTS			
16	Tav. 2 202398-0-10	1	tappo	plug			
16	Tav. 10 204891-0-10	1	molla premi piedino	spring			
17	203187-0-10	1	vite	screw			

Rimoldi

VARIANTE PER

VARIATION FOR

329-00-2CD-06

329-00-2CD-07
329-00-2CD-13
329-01-2CD-02
329-22-2CD-04
329-23-2CD-04

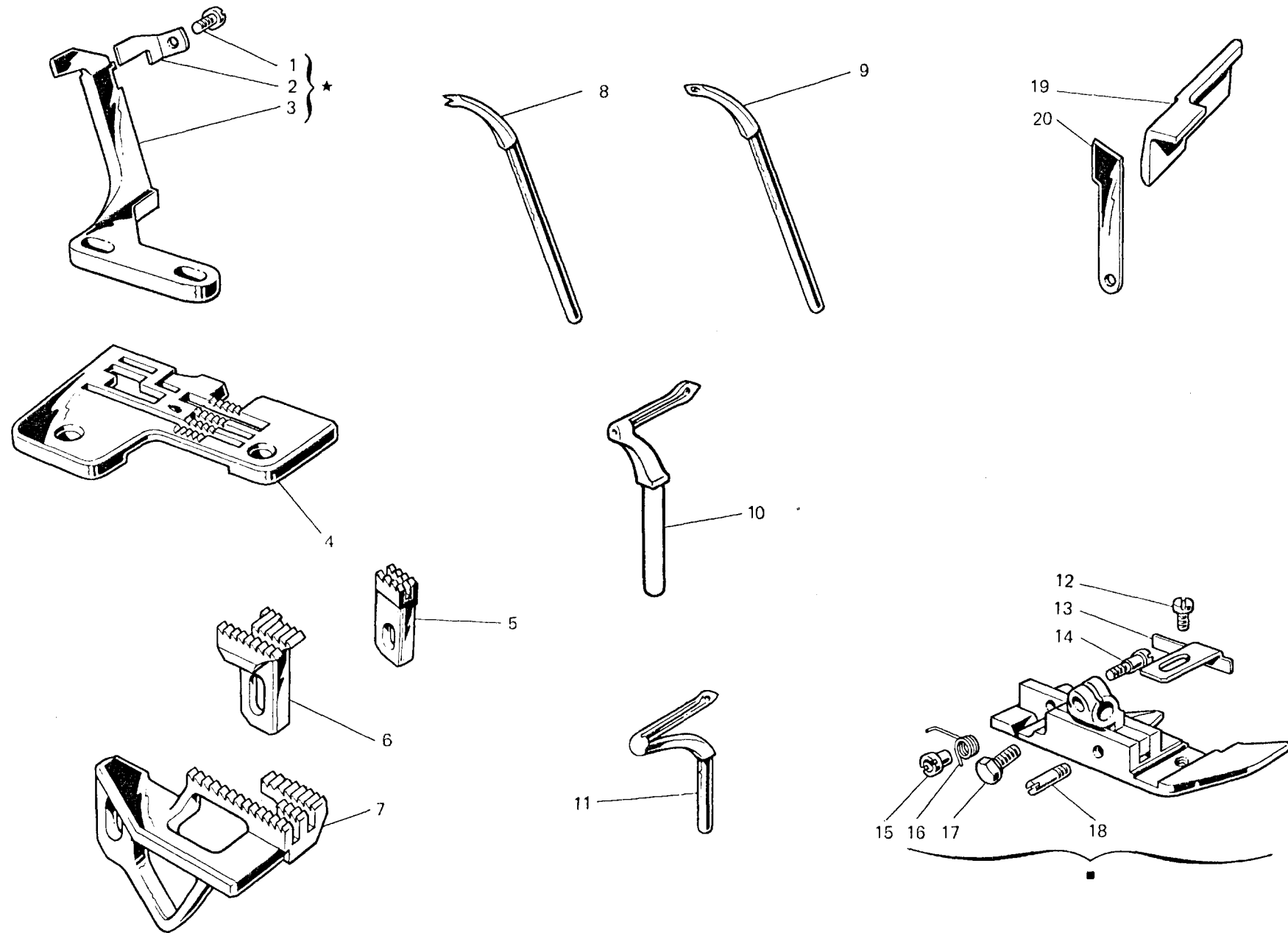

Fig. N. Abb. N.	Part. N. Bestell N. Piece N. Pieza N.	Ct. Anzahl	DESCRIZIONE	DESCRIPTION	BENENNUNG	DESCRIPTION	DESCRIPCION
★	204862-4-10	1	gruppo salva ago e spingi asola	rear and front needle guard assembly			
1	741431-0-00	1	vite	screw			
2	204861-0-10	1	spingi asola	front needle guard			
3	204863-0-10	1	salva ago	rear needle guard			
4	205025-0-10	1	placca ago	needle plate			
5	202609-0-10	1	griffino largh.costa 5,5 mm	feed-dog bight width 5,5 mm.			
6	205011-0-10	1	griffa sussidiaria	subsidiary feed dog			
7	205007-0-10	1	griffa principale	main feed-dog			
8	202092-0-10	1	crochet sup.cieco cucit.a 4 fili	upper looper (blind)			
9	204033-0-10	1	crochet sup.cieco cucit.a 5 fili	upper looper (blind)			
10	204676-0-10	1	crochet punto sicurezza	looper			
11	202413-0-10	1	crochet inferiore	lower looper			
12	741413-0-00	1	vite	screw			
13	204878-0-10	1	piastrina	plate			
14	204889-0-10	1	vite	screw			
15	204895-0-10	1	bussola filettata	bush			
16	204894-0-10	1	molla	spring			
17	204947-0-10	1	vite	screw			
18	204869-0-10	1	spina	pin			
19	207003-2-00	1	coltello superiore	upper knife			
20	207020-2-00	1	coltello inferiore	lower knife			
■	205070-3-11	1	pedino completo	presserfoot assembly			
	Tav. 32		SOLO A RICHIESTA	ONLY ON REQUEST			
6	205013-2-11	1	griffa sussidiaria	subsidiary feed-dog			
	205064-0-10	1	griffa sussidiaria	subsidiary feed-dog			
	205065-0-10	1	griffa sussidiaria	subsidiary feed-dog			
7	205009-2-11	1	griffa principale	main feed-dog			
	205059-0-10	1	griffa principale	main feed-dog			
	205060-0-10	1	griffa principale	main feed-dog			
10	204675-0-10	1	crochet punto sicurezza	looper			
19	203783-0-10	1	coltello superiore	upper knife			
	203759-0-10	1	coltello superiore	upper knife			
	207004-2-00	1	coltello superiore con placchetta	upper knife			
20	204693-0-10	1	coltello inferiore	lover knife			
	Tav. 3						
33	781306-0-20	1	targhetta classe testa	head class plate			
	Tav. 4						
1	205051-4-11	1	pressafilo completo	thread presser assembly			
5	205049-0-10	1	pastiglia	plug			
17	205042-2-11	1	passafilo dell'ago	threadt needle guide			
19	205055-0-10	1	cavallotto guida filo	bracket thread guide			
	Tav. 8						
14	205125-0-10	1	bussolina distanziale	bush			
	Tav. 9						
★	206431-4-00	1	cinematismo comando ago	needle control assembly			
1	206515-0-00	1	leva	lever			
27	206833-4-00	1	barra ago con morsetto e fig.24-25	needle bar with clamp fig.24-25			
28	765200-6-10	1	ago sistema RIM 27 fin 100	needle RIM27 fin.100			
	Tav. 10						
16	205042-0-10	1	molla premipiedino	spring			
	Tav. 11						
17	205024-0-10	1	spingi asola	front needle guard			
	Tav. 14						
17	765200-6-10	10	ago sistema RIM 27 fin 100	needle RIM27 fin.100			

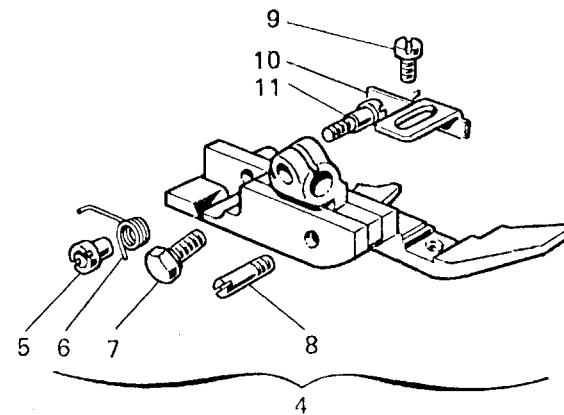
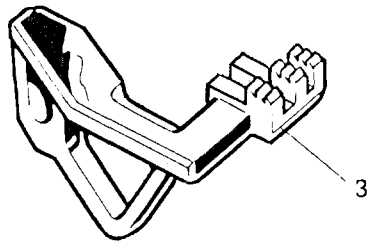
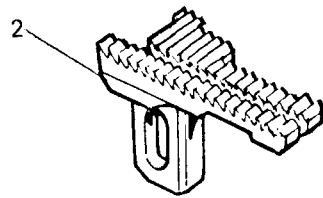
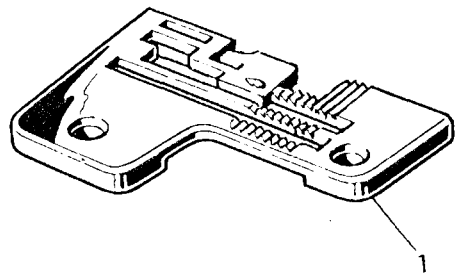
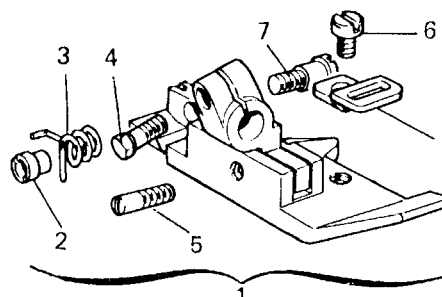

Fig. N. Abb. N.	Part. N. Bestell N. Piece N. Pieza N.	Qt. Anzahl	DESCRIZIONE	DESCRIPTION	BENENNUNG	DESCRIPTION	DESCRIPCION
1	205026-0-10	1	placca ago largh.costa 5 mm.	needle plate bight width 5 mm.			
2	205066-0-10	1	griffa sussidiaria	subsidiary feed dog			
3	205061-0-10	1	griffa principale	main feed dog			
4	205110-3-11	1	pedino completo	presserfoot assembly			
5	204895-0-10	1	bussola filettata	bush			
6	204894-0-10	1	molla	spring			
7	204947-0-10	1	vite	screw			
8	204869-0-10	1	spina	pin			
9	741413-0-00	1	vite	screw			
10	205112-0-10	1	piastrina	plate			
11	205889-0-10	1	vite	screw			
			<u>Tav. 3</u>				
33	781300-0-20	1	targhetta classe testa	head class plate			
			<u>Tav. 4</u>				
10	724432-0-00	1	vite	screw			
			<u>Tav. 32</u>				
19	203783-0-10	1	coltello superiore	upper knife			
	203759-0-10	1	coltello superiore	upper knife			
	207004-2-00	1	coltello superiore con placchetta	upper knife			
20	204693-0-11	1	coltello inferiore	lower knife			
			<u>Tav. 33</u>				
2	205067-0-10	1	griffa sussidiaria	subsidiary feed dog			
3	205062-0-10	1	griffa principale	main feed dog			
			SOLO A RICHIESTA	ONLY ON REQUEST			

Fig. N. Abb. N.	Part. N. Bestell N. Pieca N. Pieza N.	Qt. Anzahl	DESCRIZIONE	DESCRIPTION	BENENNUNG	DESCRIPTION	DESCRIPCION
33	Tav. 3 781300-0-20	1	targhetta classe testa	head class plate			
10	Tav. 4 724432-0-00	1	vite	screw			
28	Tav. 9 765200-6-90	2	ago sistema RIM27 fin.90	needle RIM27 fin.90			
17	Tav. 14 765200-6-90	10	ago sistema RIM27 fin.90	needle RIM27 fin.90			
4	Tav. 31 205026-0-10	1	placca ago largh.costa 5 mm.	needle plate bight width 5 mm.			
6	205066-0-10	1	griffa sussidiaria	subsidiary feed dog			
7	205061-0-10	1	griffa principale	main feed dog			
			SOLO A RICHIESTA	ONLY ON REQUEST			
6	Tav. 32 205067-0-10	1	griffa sussidiaria	subsidiary feed dog			
7	205062-0-10	1	griffa principale	main feed dog			
19	203783-0-10	1	coltello superiore	upper knife			
	203759-0-10	1	coltello superiore	upper knife			
	207004-2-00	1	coltello superiore con placchetta	upper knife			
20	204693-0-11	1	coltello inferiore	lower knife			

Fig. N. Abb. N.	Part. N. Bestell N. Pieze N. Pieza N.	Qt. Anzahl	DESCRIZIONE	DESCRIPTION	BENENNUNG	DESCRIPTION	DESCRIPCION
	<u>Tav. 35</u>						
1	205033-3-11	1	piedino completo	presserfoot assembly			
2	204895-0-10	1	bussola filettata	bush			
3	204894-0-10	1	molla	spring			
4	204947-0-10	1	vite	screw			
5	204869-0-10	1	spina filettata	pin			
6	741526-0-00	1	vite	screw			
7	204889-0-10	1	vite	screw			
8	205015-0-10	1	squadretta	bracket			
	<u>Tav. 3</u>						
33	781300-0-20	1	targhetta classe testa	head class plate			
	<u>Tav. 4</u>						
10	724432-2-00	1	vite	screw			
	<u>Tav. 9</u>						
28	765200-6-90	2	ago sistema RIM27 fin.90	needle RIM27 fin. 90			
	<u>Tav. 14</u>						
17	765200-6-90	10	ago sistema RIM27 fin.90	needle RIM27 fin.90			
			SOLO A RICHIESTA	ONLY ON REQUEST			
	<u>Tav. 32</u>						
19	203783-0-10	1	coltello superiore	upper knife			
	203759-0-10	1	coltello superiore	upper knife			
	207004-2-00	1	coltello superiore con placchetta	upper knife			
20	204693-0-11	1	coltello inferiore	lower knife			



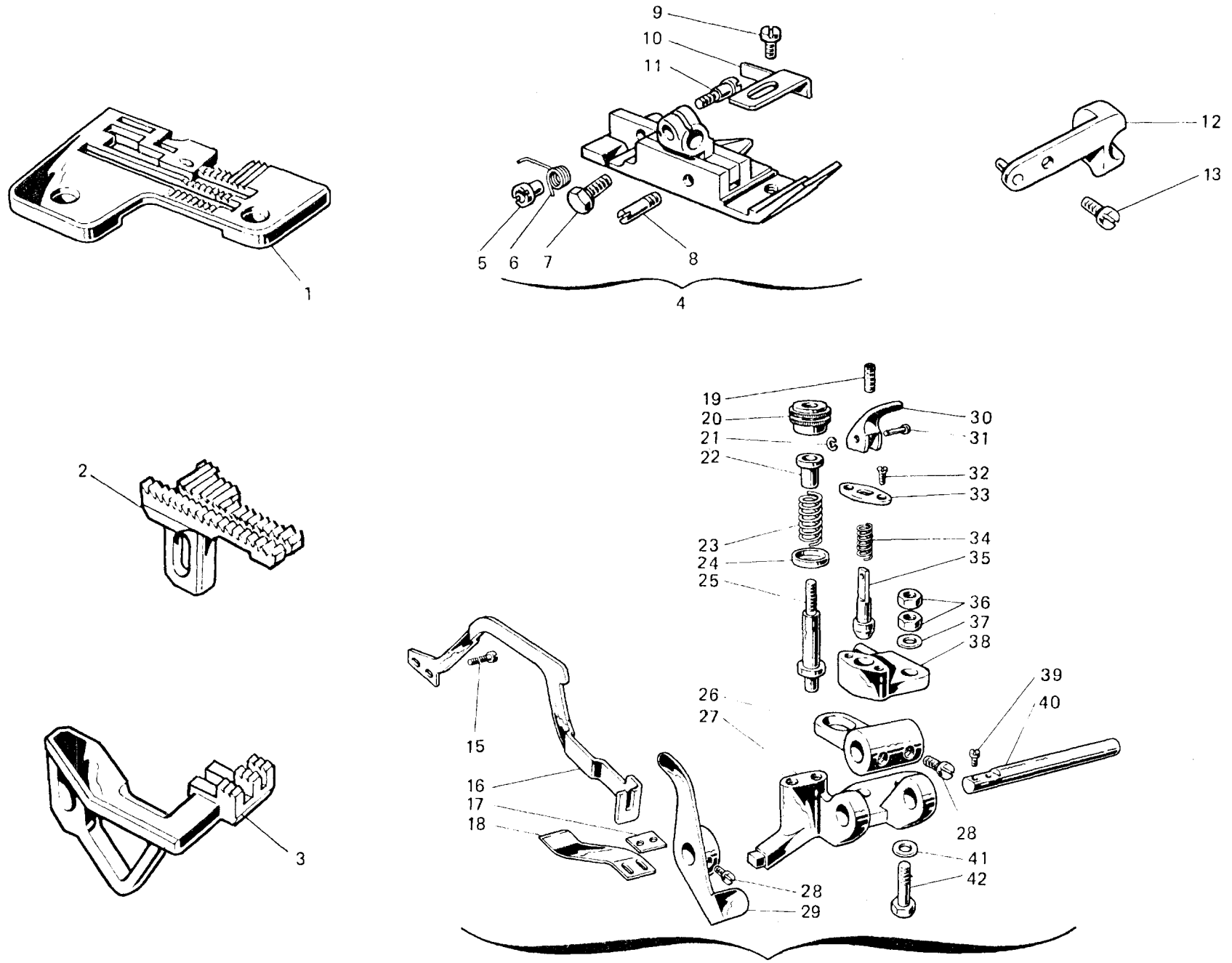

Fig. N. Abb. N.	Part. N. Bestell N. Piece N. Pieza N.	Qt. Anzahl	DESCRIZIONE	DESCRIPTION	BENENNUNG	DESCRIPTION	DESCRIPCION
1	205026-0-10	1	placca ago largh.costa 5 mm.	needle plate bight width 5 mm.			
2	205014-0-10	1	griffa sussidiaria	subsidiary feed dog			
3	205010-0-10	1	griffa principale	main feed dog			
4	205034-3-11	1	pedino completo	presserfoot assembly			
5	205895-0-10	1	bussola filettata	bush			
6	204894-0-10	1	molla	spring			
7	204947-0-10	1	vite	screw			
8	204869-0-10	1	spina	pin			
9	741431-0-00	1	vite	screw			
10	204880-0-10	1	piastrina	plate			
11	204889-0-10	1	vite	screw			
12	203193-2-10	1	squadretta con spina	bracket with pin			
13	721443-0-10	1	vite	screw			
14	204915-4-12	1	pieghettatore completo	folding device			
15	300483-0-10	2	vite	screw			
16	206923-0-00	1	leva alza pieghettatore	lever			
17	204964-0-00	1	piastrina	plate			
18	204916-0-10	1	lamina	sheet			
19	729013-2-00	1	vite	screw			
20	200699-0-10	1	pomolo	knob			
21	700205-0-00	1	anello elastico	spring ring			
22	200074-0-10	1	bussola	bush			
23	204937-0-10	1	molla	spring			
24	200821-0-10	1	scodellino	cup			
25	200698-0-10	1	perno	pin			
26	204926-0-10	1	leva premi lamina	lever			
27	204914-0-10	1	corpo del pieghettatore	folding body			
28	721434-2-00	4	vite	screw			
29	204924-2-10	1	leva	lever			
30	206909-0-00	1	leva per puntale	lever			
31	202100-0-10	1	spina	pin			
32	744533-0-00	2	vite	screw			
33	204935-0-10	1	piastrina	plate			
34	204938-2-00	1	molla premi puntale	spring			
35	204936-0-10	1	puntale	cup			
36	746021-2-00	2	dado	nut			
37	704216-2-00	1	rondella	washer			
38	204927-0-10	1	sostegno	support			
39	741675-2-00	2	vite	screw			
40	204918-0-10	1	perno porta lamina	pin			
41	704424-2-00	1	rondella	washer			
42	204934-0-10	1	vite	screw			
	<u>Tav.3</u>						
33	781300-0-20	1	targhetta classe testa	head class plate			

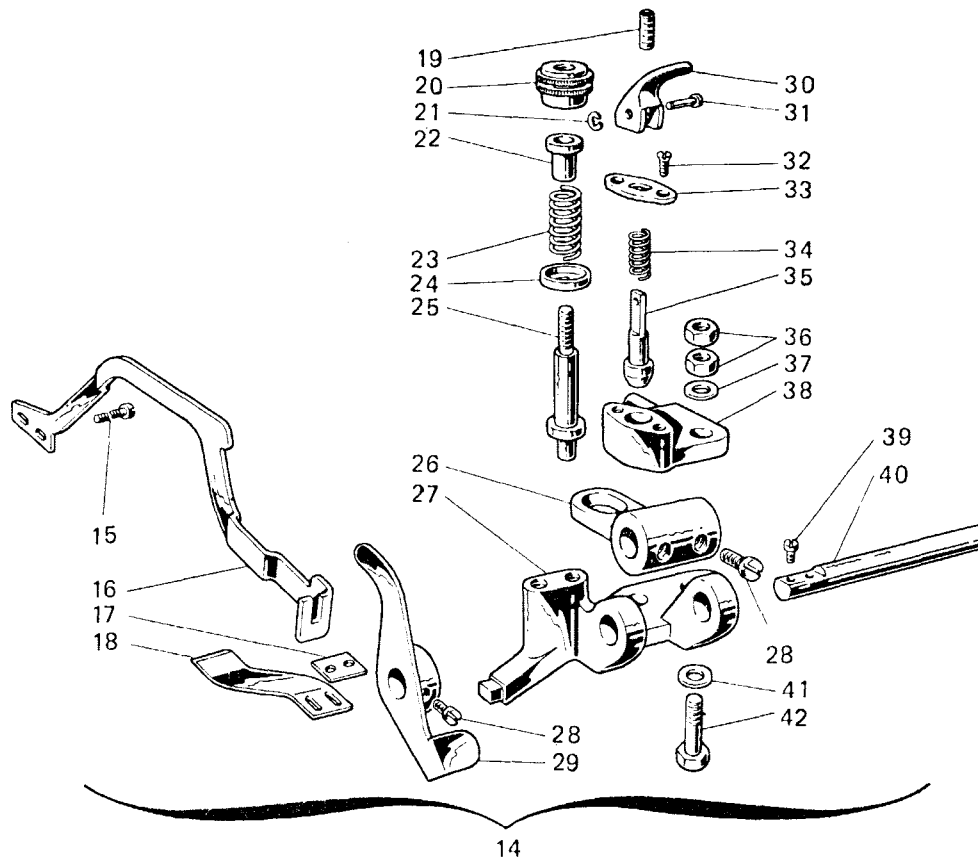
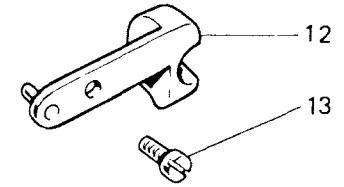
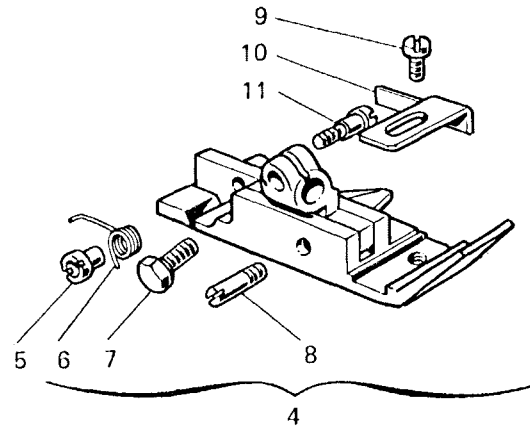
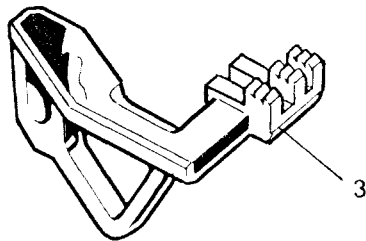
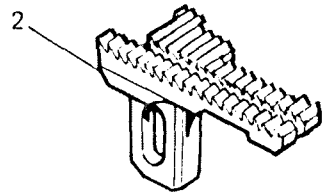
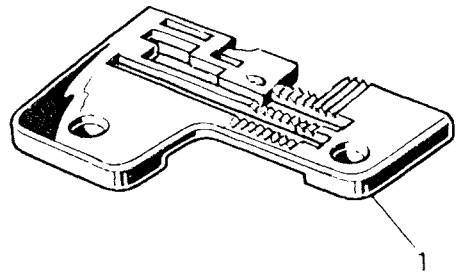

Fig. N. Abb. N.	Part. N. Bestell N. Piece N. Pieza N.	Qt. Anzahl	DESCRIZIONE	DESCRIPTION	BENENNUNG	DESCRIPTION	DESCRIPCION
10	<u>Tav. 4</u> 724432-0-00	1	vite	screw			
			SOLO A RICHIESTA	ONLY ON REQUEST			
19	<u>Tav. 32</u> 203783-0-10	1	coltello superiore	upper knife			
	203759-0-10	1	coltello superiore	upper knife			
	207004-2-00	1	coltello superiore con placchetta	upper knife			
20	204693-0-11	1	coltello inferiore	lower knife			
2	<u>Tav.36</u> 205067-0-10	1	griffa sussidiaria	subsidiary feed dog			
3	205062-0-10	1	griffa principale	main feed dog			
			PEZZI ANNULLATI	CANCELLED PARTS			
16	<u>Tav. 2</u> 202398-0-10	1	tappo	plug			
16	<u>Tav. 10</u> 205042-0-11	1	molla premipedino	spring			
17	203187-0-10	1	vite	screw			

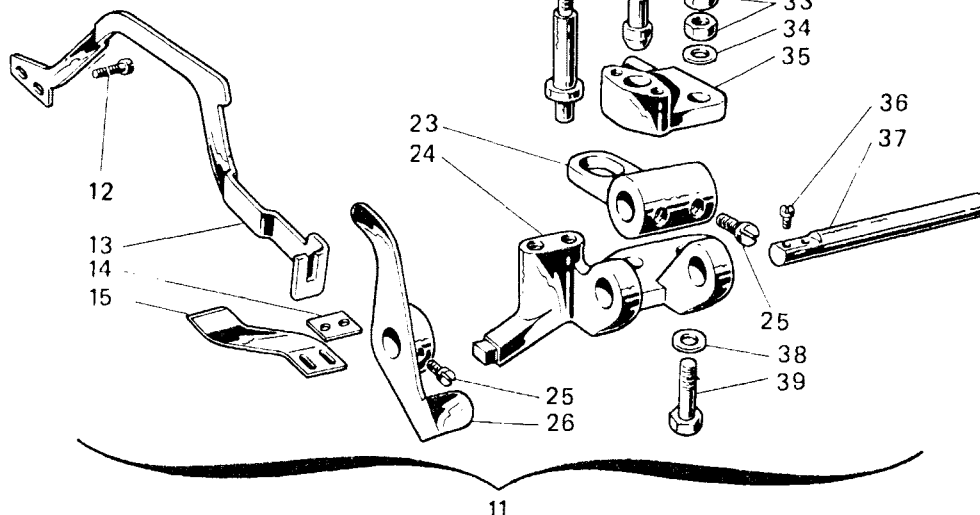
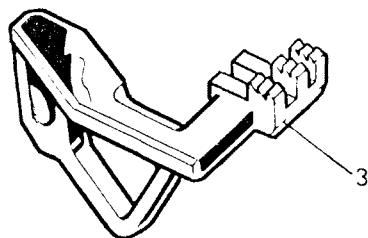
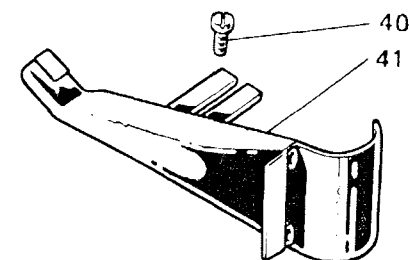
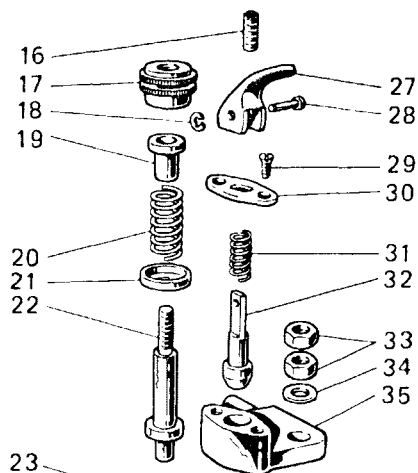
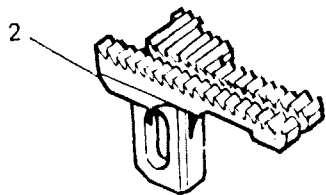
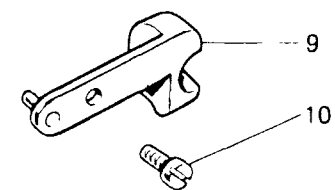
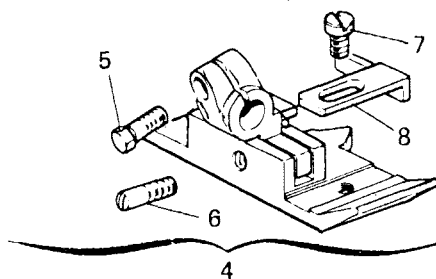
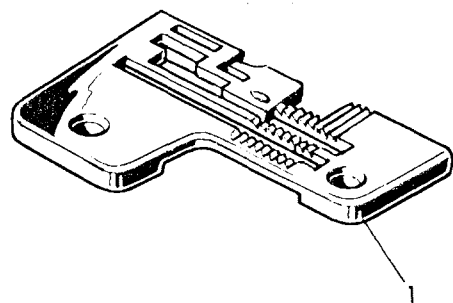

Fig. N. Abb. N.	Part. N. Bestell N. Piece N. Pieza N.	Ct. Anzahl	DESCRIZIONE	DESCRIPTION	BENENNUNG	DESCRIPTION	DESCRIPCION
1	205026-0-10	1	placca ago largh.costa 5 mm.	needle plate bight width 5 mm.			
2	205014-0-10	1	griffa sussidiaria	subsidiary feed dog			
3	205010-0-10	1	griffa principale	main feed dog			
4	205035-3-11	1	pieдино completo	presserfoot assembly			
5	204947-0-10	1	vite	screw			
6	204869-0-10	1	spina	pin			
7	741431-0-00	1	vite	screw			
8	204881-0-10	1	piastrina	plate			
9	203193-2-10	1	squadretta con spina	bracket			
10	721443-0-10	1	vite	screw			
11	204915-4-12	1	pieghettatore completo	folding device			
12	300483-0-10	2	vite	screw			
13	206923-0-00	1	leva alza pieghettatore	lever			
14	204264-0-00	1	piastrina	plate			
15	204916-0-10	1	lamina	sheet			
16	729013-2-00	1	vite	screw			
17	200699-0-10	1	pomolo	knob			
18	700205-0-00	1	anello elastico	spring ring			
19	200074-0-10	1	bussola	bush			
20	204937-0-10	1	molla	spring			
21	200821-0-10	1	scodellino	cup			
22	200698-0-10	1	perno	pin			
23	204926-0-10	1	leva premi lamina	lever			
24	204914-0-10	1	corpo del pieghettatore	folding device			
25	721434-0-00	4	vite	screw			
26	204924-2-10	1	leva	lever			
27	206909-0-00	1	leva per puntale	lever			
28	202100-0-10	1	spina	pin			
29	744533-0-00	2	vite	screw			
30	204935-0-10	1	piastrina	plate			
31	204938-2-00	1	molla premi puntale	spring			
32	204936-0-10	1	puntale	cup			
33	746021-2-00	2	dado	nut			
34	704216-2-00	1	rondella	washer			
35	204927-0-10	1	sostegno	support			
36	741675-2-00	2	vite	screw			
37	204918-0-10	1	perno porta lamina	pin			
38	704424-2-00	1	rondella	washer			
39	204934-0-10	1	vite	screw			
40	721444-2-00	2	vite	screw			
41	204930-2-10	1	guida	guide			
33	Tav.3 781300-0-20	1	targhetta classe testa	head class plate			

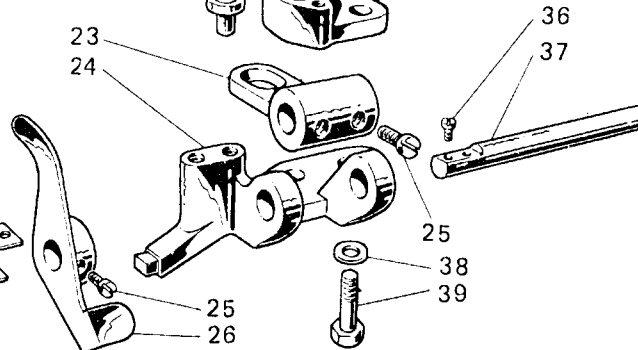
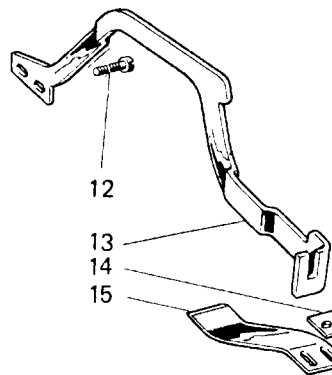
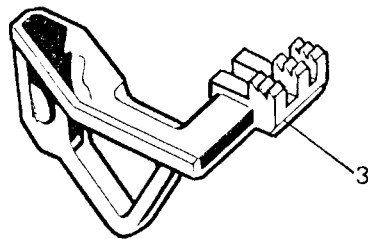
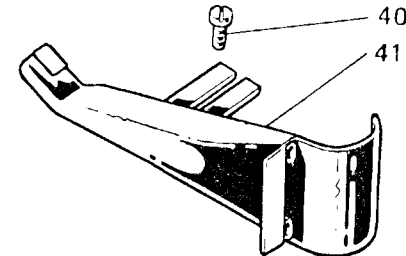
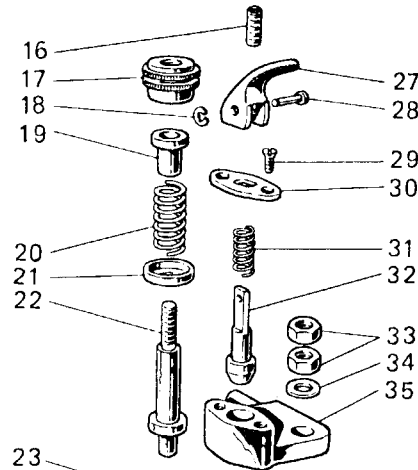
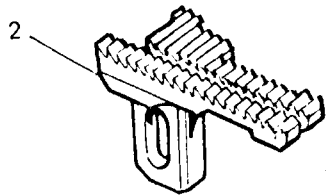
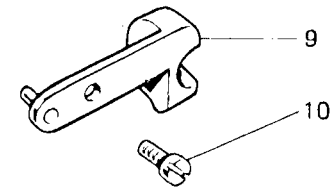
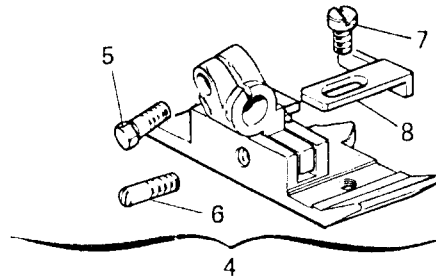
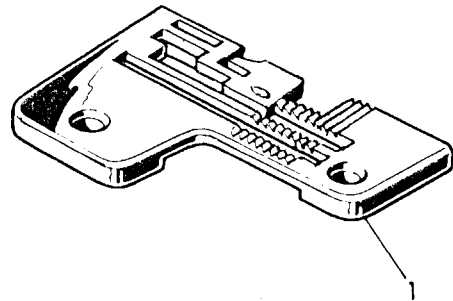

Fig. N. Abb. N.	Part. N. Bestell N. Piece N. Pieza N.	Ct. Anzahl	DESCRIZIONE	DESCRIPTION	BENENNUNG	DESCRIPTION	DESCRIPCION
10	<u>Tav. 4</u> 724432-0-00	1	vite	screw			
			SOLO A RICHIESTA	ONLY ON REQUEST			
19	<u>Tav. 32</u> 203783-0-10	1	coltello superiore	upper knife			
	203759-0-10	1	coltello superiore	upper knife			
	207004-2-00	1	coltello superiore con placchetta	upper knife			
20	204693-0-11	1	coltello inferiore	lower knife			
2	<u>Tav. 37</u> 205067-0-10	1	griffa sussidiaria	subsidiary feed dog			
3	205062-0-10	1	griffa principale	main feed dog			
41	204958-2-10	1	guida	guide			
			PEZZI ANNULLATI	CANCELLED PARTS			
16	<u>Tav. 2</u> 202398-0-10	1	tappo	plug			
16	<u>Tav. 10</u> 205042-0-11	1	molla premipedino	spring			
17	203187-0-10	1	vite	screw			



Rockwell-Rimoldi S.p.A.

9, via Vespri Siciliani — 20146 Milano (Italy)
Telefono: 470.152 - 470.081 — Telex: 332280
Printed in Italy

From the library of: Superior Sewing Machine & Supply LLC